



Models GC-AC3, GC-AC3-A, GC-AC4, GC-AC5-A EZ Page Industrial Intercom

TABLE OF CONTENTS

Confidentiality Notice	1
General Information	1
Product Overview	1
Balanced and Unbalanced Systems	1
System Requirements	2
Cable Distance Limitations	2
Installation	2
Internal Settings	3
Power Connection	4
Mounting Instructions	4
Connection Instructions	4
System Line Balance	4
System Interconnect	5
Operation	6
Speaker Volume	6
To make a page	6
Maintenance	6
Internal Fuse Replacement	6
Troubleshooting	7
Specifications	8
Electrical	8
Amplifier PCBA	8
Integral Speaker Assembly	8
General	8
CE Declaration of Conformity	9

EZ Page Industrial Intercom

Models GC-AC3, GC-AC3-A, GC-AC4, GC-AC5-A

Confidentiality Notice

This manual is provided solely as an operational, installation, and maintenance guide and contains sensitive business and technical information which is confidential and proprietary to GAI-Tronics. GAI-Tronics retains all intellectual property and other rights in or to the information contained herein, and such information may only be used in connection with the operation of your GAI-Tronics product or system. This manual may not be disclosed in any form, in whole or in part, directly or indirectly, to any third party.

General Information

Product Overview

GAI-Tronics' EZ Page Intercoms are designed for two-way communication in non-hazardous, light industrial applications. All units are factory configured for the *Listen/Talk system*.

Listen/Talk system. The press-to-talk switch must be depressed as long as the operator talks. Releasing the switch deactivates the microphone and returns the unit to the listen mode.

Master/Slave system. Not available with this model.

Balanced and Unbalanced Systems

The EZ Page system is a balanced system; however, it can be adapted for use in an unbalanced system. If interfacing this equipment with other similar products on the market, determine if your system is balanced or unbalanced.

The setting of an internal jumper and the external wiring interconnection scheme are different in a balanced system and an unbalanced system. Refer to the appropriate installation instructions provided in this manual.

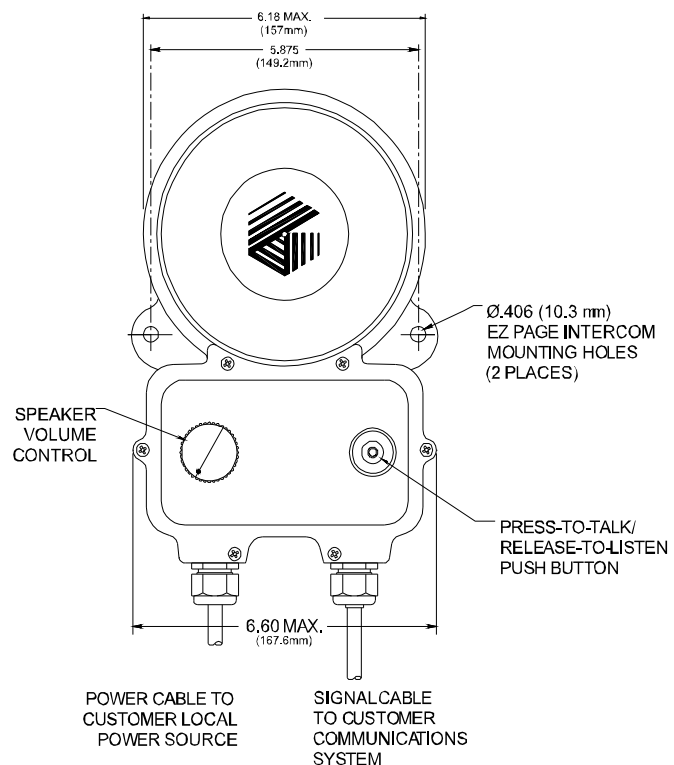

Figure 1. Intercom Outline Diagram

System Requirements

Each unit requires local power within approximately 1.5 m of unit. A junction box within approximately 1.5 m of unit for interconnection of unit's audio cable to system cable.

Note: The installation shall comply with national requirements.

Models	Input Voltage	Interconnection (Customer-supplied)
GC-AC3 GC-AC3-A GC-AC5-A	230 V ac ± 10%	Junction box or plug rated for this voltage.
GC-AC4	115V ac ± 10%	Junction box or plug rated for this voltage

Cable Distance Limitations

Note: Calculations are based on the use of 18 AWG twisted pair wire.

Audio Pair

Maximum distance from the line balance is approximately 1.6 km. Maximum distance between the two end units is approximately 3.2 km.

System Cable

Recommend use of twisted pair cable (1.5mm²) between stations for maximum system hum/noise immunity. Extreme hum/noise areas may require shielded twisted pair cable.

Models GC-AC3, GC-AC3-A and GC-AC4 require single twisted pair cable.

Model GC-AC5-A requires twin twisted pair cable, either as 2 individual cables or 2 twisted pairs within the same cable.

Installation

Since a good installation is important in obtaining the best possible performance of the communications system, determine the operating mode of each unit and carefully plan the overall installation before actual work is started. Read the entire procedure and the many suggestions offered to help you plan your installation.

DANGER

Do not install in a hazardous area.

Use in safe, non-classified, non-hazardous areas only.

WARNING

Please adhere to all the following safety and operating instructions on the unit and in the installation manual:

- Ensure that the installation is in accordance with all local applicable electrical codes.
- Disconnect power to the unit before opening or servicing to avoid possible damage to equipment or personal injury.
- Avoid running system cable near high voltage/high electromagnetic sources.
- Avoid servicing the unit during electrical storms.
- Do not touch non-insulated wires.

Internal Settings

The following procedure describes how to change the internal settings. If the Intercom is to be used as a *Listen/Talk unit* in a *balanced line* system, then no changes to the internal PCBA's jumper or switch settings are required.

WARNING

Disconnect power to unit before opening to avoid possible damage to equipment or personal injury.

1. Disconnect power to the unit.
2. Loosen and remove the six screws securing the front cover.
3. Lift out the front panel assembly and tilt to the left. Use caution to ensure that no unnecessary strain is placed on the attached wiring harnesses.
4. Send level adjustment: (Not fitted for models GC-AC3-A and GC-AC5-A). The adjustment pot is factory set to its mid point. If the level needs to be changed, adjust the pot one turn at a time and replace the front panel before reapplying power. Check for correct operation by pressing the Talk button and confirming the send level to the interfacing equipment.
5. If operating in an unbalanced cable system, reposition the PCBA's jumper P5/J5 from the BAL position to the UNBAL position. See Figure 2.
6. Reinsert the front panel assembly into the rear housing. Ensure that no wires are between the front panel's gasket and the housing's sealing surface which could be pinched.
7. Reinsert the six screws into the front cover and tighten securely.
8. Reapply the unit power and check for proper operation.

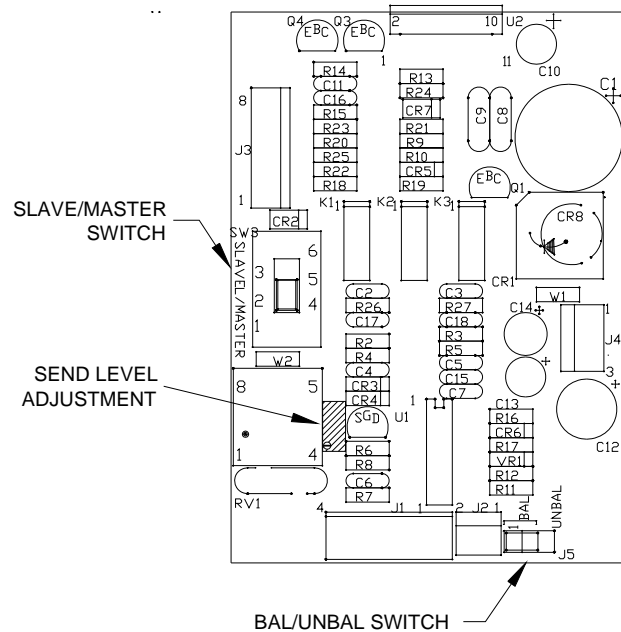

Figure 2. PCBA Outline Detail

Power Connection

WARNING

- Installation techniques must comply with all applicable electrical safety hazards/electrical codes.
- Remove local power before opening the unit or before performing any service.

Input Voltage	Model	Conductor 1		Conductor 2		Conductor 3	
		Live	Brown	Neutral	Blue	Safety Ground	Green/Yellow
230 V ac (See Note)	GC-AC3 GC-AC3-A GC-AC5-A	Live	Brown	Neutral	Blue	Safety Ground	Green/Yellow
115 V ac (See Note)	GC-AC4	Live	Brown	Neutral	Blue	Safety Ground	Green/Yellow

Notes:

1. For all models, termination of the integral primary power cable must be made using a CE-marked junction box. If a customer-supplied plug is desired for interconnection, the plug must be CE-marked and rated for such purposes.

Mounting Instructions

The wall's mounting surface composition and hardware to be used (customer-supplied) **must be suitable** to withstand the unit's weight to prevent damage and/or personal injury.

There are two 10.4 mm diameter mounting holes spaced 149.3mm apart from each other (see Figure 1). They are located in the mounting flanges located on each side of the unit's housing. The suggested mounting height for all station enclosures is 137 cm from the floor to the centerline of the enclosure.

Connection Instructions

System Line Balance

Each system requires termination of the audio pair wires with a 1 kilohm, 1 watt resistor termination assembly included with each unit. The line balance resistor assembly is made for easy installation into the customer-supplied junction box. *Only one line balance resistor assembly is needed per system.*

For cable runs that are approximately 0.75 mile (1.2 km) or longer, it is recommended that the resistor assembly be installed in a junction box that is close to the center of the system.

System Interconnect

Refer to the interconnection diagram that is appropriate to the type of system you are installing. In each of the figures, the R_{bal} symbol represents the system line balance resistor assembly.

Reminder about balanced and unbalanced systems: If interconnecting to an unbalanced system, be sure to move the Intercom's internal jumper (P5/J5) to the UNBAL position. When set to UNBAL, the red conductor is the audio signal and blue is the common.

Note that model GC-AC5-A has 2 signal pairs as shown below: one audio pair and one PTT control pair. This model is only suitable for connection to GAI-Tronics controller 019-02-0042-002.

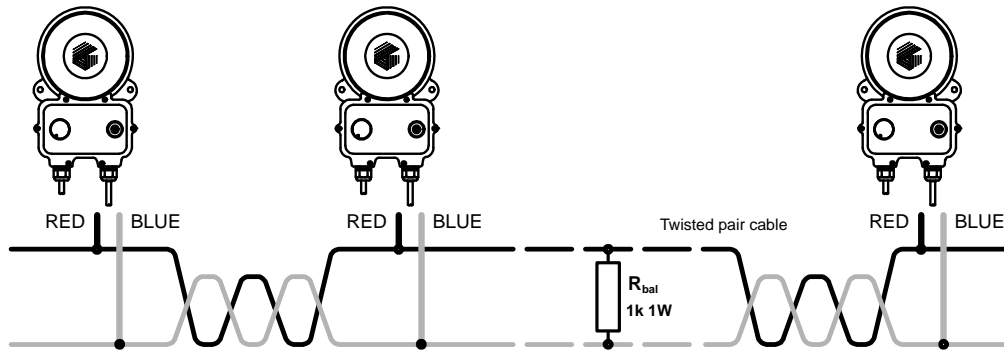

System Interconnect, EZ Page to EZ Page. Balanced.

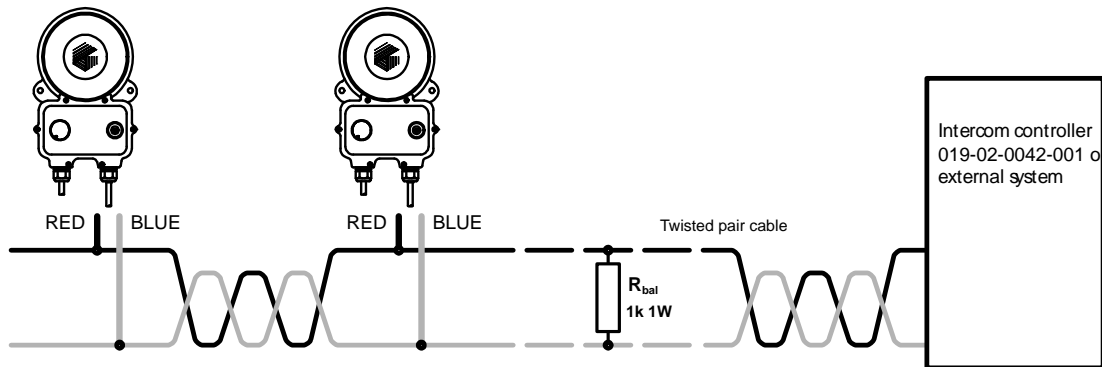

System Interconnect, EZ Page to other system, or GAI-Tronics intercom controller. Balanced.

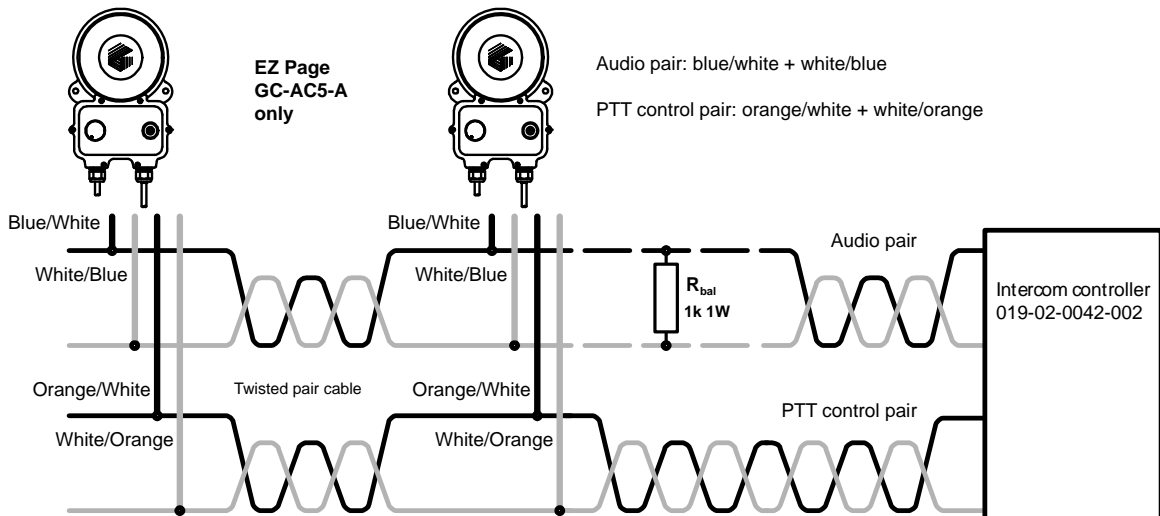

System Interconnect, EZ Page to GAI-Tronics intercom controller with AMI interface. Balanced.

Operation

Speaker Volume

Allows the user to adjust the received audio level between 10% and 100% of the output.

To make a page

Unit default: Listen mode

To make a page, operate the “press to talk” switch and talk into the speaker, which also acts as the microphone. Other units in the system, which are already in the listen mode, will broadcast the page from their speakers. Releasing the switch deactivates the microphone and returns the unit to the listen mode.

Maintenance

Internal Fuse Replacement

The fuse is located at the end of the terminal block. To reduce the risk of fire, replace fuses only with the same type and value as follows:

- For Models GC-AC3, GC-AC3-A, GC-AC5-A: HBC 5 x 20mm 250 mA - Anti-surge ceramic (1500 A breaking capacity).
- For Model GC-AC4: HBC 5 x 20mm 500 mA - Anti-surge ceramic (1500 A breaking capacity).

Troubleshooting

General troubleshooting suggestion: Periodically check for frayed or cracked wiring, loose connections or signs of corrosion inside and outside of the unit.

Problem	Possible Cause	Possible Solution
No audio is received at unit	Unit's speaker is not turned on (muted) Local unit's speaker volume control is turned counterclockwise Internal fuse blown	Check that local power is available. Adjust volume control to desired level. Replace fuse with exact voltage/fuse rating replacement. The fuse is located at the end of the terminal block.
Both paged audio and received audio is low	Short, low resistance across audio pair in system cable	Correct system wiring.
Listen/Talk configured unit can't communicate to another Listen/Talk configured unit	Possible system wiring error	Correct system wiring.
Acoustic feedback when making a page	Units are positioned too close or oriented toward each other	Reorient units away from each other or reduce speaker volume level.
Unit is always in the talk mode	Internal Mode switch set to "Slave"	Reposition internal mode switch to L/MASTER.
Excessive static/electromagnetic interference	System cable is routed too close to high voltage, high electromagnetic sources.	Reroute system cable away from high voltage, high electromagnetic sources. Use shielded system cable.

Specifications

Electrical

Models GC-AC3, GC-AC3-A, GC-AC5-A:

Voltage..... 207/253 V ac range, 50/60 Hz, (230 V ac, 50 Hz, nominal)
 Power Consumed (at nominal)..... Standby/Max. Speaker Out (8 watts)
 6.9 VA, 4 W/27 VA, 22 W

Model GC-AC4:

Voltage..... 104/126 V ac range, 50/60 Hz, (115 V ac, 50 Hz, nominal)
 Power Consumed (at nominal)..... Standby/Max. Speaker Out (8 watts)
 6.9 VA, 4 W/27 VA, 22 W

Amplifier PCBA

Frequency Response..... 250-8 kHz, +0/-3 dB (Ref to 1K), 155-12 kHz, (-6 dB)
 Distortion1% maximum THD @ 1000 Hz, 8 watts
 Gain..... 25 dB nominal (listen mode), Variable see **Internal setting**
 Input sensitivity for rated output @ 1kHz 310 mV_{RMS}
 Controls..... Balanced/Unbalanced jumper, L/Master-Slave mode switch
 Input Impedance..... 4,800 ohms (listen mode, Bal)(Ref. to 1 kHz, Vol. CW)
 Hum/Noise below rated output -64 dB minimum

Integral Speaker Assembly

Speaker Rating 30 watts maximum
 Speaker Impedance 4 ohms
 Speaker Frequency Response 250-5000 ohm (nom) (-6 dB)
 Speaker SPL..... 113 dB
 (Test based on IEC 268-5, measured using 8 watt @ 1 meter, pink noise, wall-mounted)

General

External Controls Speaker volume, Listen/Talk switch
 Internal Primary Fuse: GC-AC3, GC-AC3-A, GC-AC5-A . HBC 5 x 20mm 250 mA - Anti-surge ceramic
 Internal Primary Fuse: GC-AC4 HBC 5 x 20mm 500 mA - Anti-surge ceramic
 Integral cables:
 Power: GC-AC3 / GC-AC4 ~1.5m, 3 core 2.5mm² flexible cable
 Audio/Control ~1.5m, 1 twisted pair screened 16/0.2mm² PVC insulated cable
 Audio/Control (GC-AC5-A only)..... ~1.5m, 2x twisted pair screened 16/0.2mm² PVC insulated cable
 PTT control (GC-AC5-A only)..... Volt-free contact, normally open, rated 30Vdc 2A max
 Enclosure Cast Aluminium
 Colour. Blue (RAL5017)
 Temperature Range (Operating & Storage) -40° to +158°F (-40° to 70°C)
 Dimensions 11.2 H x 6.97 W x 5.45 D (284.5 x 177 x 138.4 mm)
 Recommended: Maximum number of Listen/Talk units per system 20
 Shipping Weight: (all models) 6.0 kg
 Unit Weight: (all models) 4.95kg

CE Declaration of Conformity

We, GAI-Tronics, of Brunel Drive, Stretton Business Park, Burton upon Trent, Staffordshire, England, DE13 0BZ, declare under our sole responsibility that the following product is in conformity with the directives and standards listed below and hold the relevant technical documentation at the above address.

Product description	EZ Page Intercom System
Product Part Number	GC-AC3 GC-AC3-A GC-AC4 GC-AC5-A

EC Directive	Standards applicable under the Directive
73/23/EC Low Voltage Directive	EN60950-1:2002
89/336/EEC EMC Directive	EN50081-1:1992 EN50082-1:1998

Date of issue	Name of authorised signatory	Position of signatory
July 2005	G. R. Lines	Business Unit manager

In accordance with European directive 91/263/EEC