

Titan

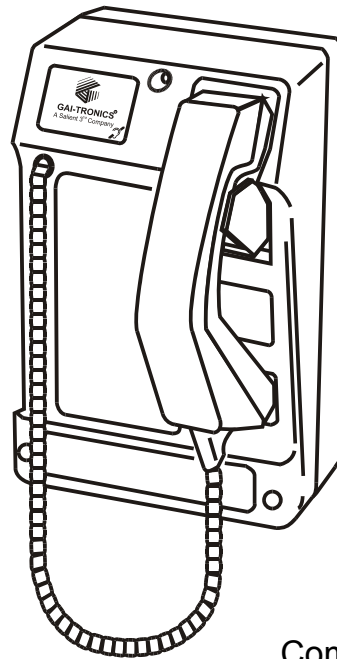

Commander

Installation and User Guide

Titan CB (1064) Commander CB (1064) Weather Resistant Telephones

GAI-TRONICS

CONTENTS

1.	Safety and Care Information.....	3
2.	Product Description	3
2.1.	Changes from previous versions.....	3
2.2.	Titan features	4
2.3.	Commander features.....	4
3.	Operation / Testing	5
3.1.	Call timer	5
3.2.	Handset integrity alert	5
4.	Installation	6
4.1.	General	6
4.2.	Emergency Services warning.....	6
4.3.	Titan	6
4.4.	Commander	7
5.	Mounting methods and dimensions	7
5.1.	General	7
5.2.	Titan	8
5.3.	Commander	12
6.	Connections and option settings.....	14
6.1.	Standard connections and timer setting	15
6.2.	Additional hook contact	15
7.	Aftercare	16
8.	Technical Specifications	17
9.	CE Declaration	19

1. Safety and Care Information

- ▲ The safety of the user/installer relies on the isolation of the telephone network and not on the earthing of the case
- ▲ The spring-loaded door (Titan models only, where fitted) can close sharply. Take care not to trap fingers etc., during installation and use.
- ▲ Please read these instructions thoroughly before starting installation. These products must be installed by competent personnel familiar with telephone installation.
- ▲ Telephone network voltages can be hazardous. Take adequate precautions when opening the case or installing. If in doubt, disconnect the telephone line elsewhere before accessing the line connections.
- ▲ For increased protection against lightning transients, attach a local earth to the main terminal block (see section 6)

2. Product Description

This manual describes the CB versions of the Titan and Commander telephone ranges. The term “CB” originally stood for “central battery”, but in modern terms means a telephone with no dialling or signalling capability – it can only seize the line or ring. Although functionally and electrically identical, (i.e. the operation and connection details are common), Titan and Commander differ physically, so the installation and mounting details are described separately.

2.1. Changes from previous versions

This manual describes an updated range of products (called ‘1064’ models) introduced in March 2005. For those familiar with GAI-Tronics’ products, the list of new or changed features is as follows:

- New terminal layout (section 6.1).
- Increased lightning protection (section 8).
- Handset integrity alert option (section 3.2).
- No separate Cap-Shunt link (ringing is permanently enabled).
- Compliance with ETSI European telephony standards (previous versions were to British standards) section 8.
- Compliance with railway EMC standards (section 8)
- Second hookswitch option (section 6.2)

For the full list of product features, please see the specifications in section 8.

2.2. Titan features

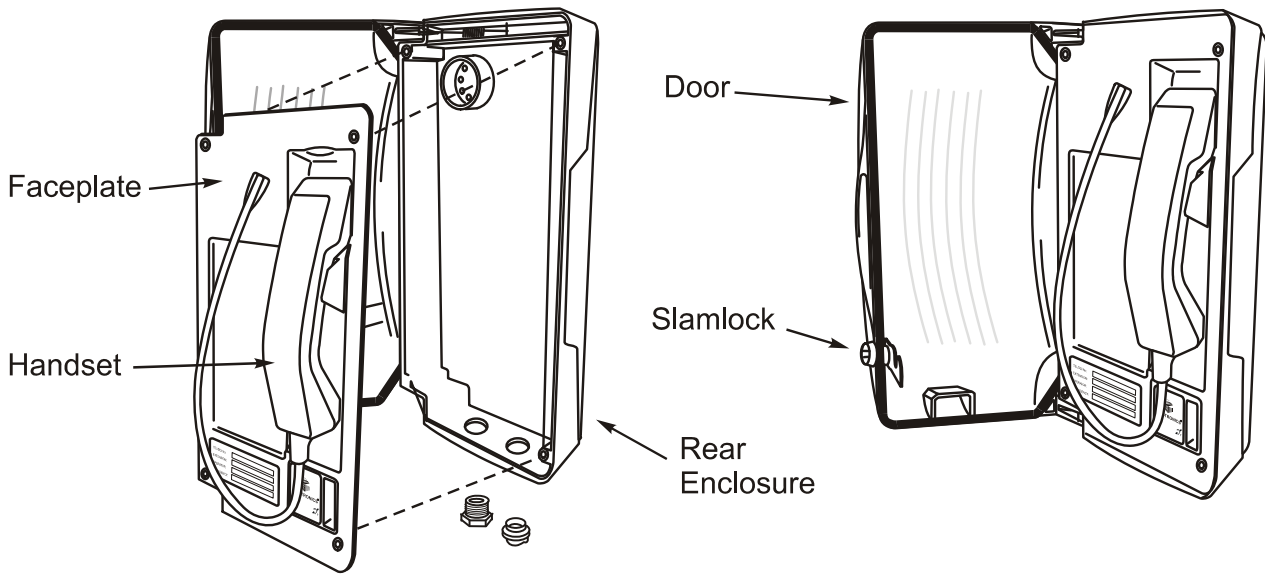

Titan is a family of rugged, weather-resistant metal-bodied telephones available with a range of handset types, keypad configurations, colours and enclosures, based around a common faceplate style.

Most Titans are equipped with a heavy-duty spring-loaded door, but models are available without door and also as faceplate only, for flush mounting.

Titan doors may be fitted with slamlocks opened by an 8mm square socket key.

2.3. Commander features

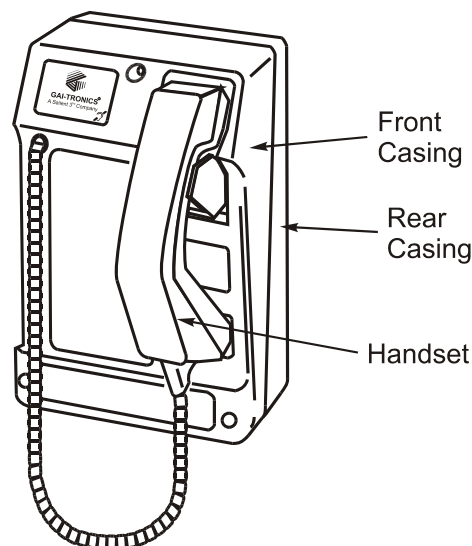

Commander is a family of rugged, weather-resistant telephones manufactured from moulded glass-reinforced polyester. A range of handset types and keypad configurations are available.

3. Operation / Testing

The CB telephone has no buttons and no means of dialling or signalling.

It can only be used to make calls where calls are routed by the exchange, for example the BT Direct Connect service or PABXs or concentrators specifically configured to do so. Seek assistance from your telephone service provider or infrastructure maintainer to configure this facility.

To make a call, lift the handset. The exchange should establish the call. When the other party answers, two way speech is possible.

To end the call, replace the handset on its cradle.

To answer a call, wait for ringing (a loud, two-tone warble), then lift the handset. Two way speech should be possible as before, and the call is ended by replacing the handset.

3.1. Call timer

The phone has a selectable call timer that can limit the maximum call duration to approximately 7 minutes.

When on, the timer forces the phone back off line after the preset time. This prevents the line remaining tied if the handset is left off-hook. The timer is factory-set to OFF by default.

3.2. Handset integrity alert

If configured, this feature will disable the call timer if the handset integrity loop is broken. This means that, if the handset is detached (for example by vandalism), the telephone will remain permanently on line even if the call timer is on.

This provides a method of alerting the signal box or control centre that the handset is damaged and needs urgent attention.

WARNING: this option should only be used on PABXs or concentrators configured to expect the alert condition. Not for use on the PSTN.

This is a factory-configured option. Telephones with this option have an internal label marked "Handset Integrity Alert, the call timer is disabled if the handset integrity loop is broken".

4. Installation

4.1. General

IMPORTANT

All possible measures must be taken to ensure water, fluid or dust does not contaminate the internal components of the telephone whilst unpacking, preparing and installing the telephone in inclement weather conditions or by negligence.

Failure to do so may invalidate your warranty.

These telephones are supplied without connection leads – cabling to the telephone network must be supplied and installed by the installer. Because of this, extra precautions must be observed: installers must ensure that they have the permission of the owner of the PABX or telephone network to which the telephone is to be connected, and that installation is carried out by trained personnel. Contact GAI-Tronics if installation service is required.

IMPORTANT

Installation details differ between the TITAN and COMMANDER product ranges –please make sure you know which product you are installing and refer to the appropriate sections below.

4.2. Emergency Services warning

These telephones are not capable of dialling, and therefore cannot make direct calls to the emergency services unless the exchange is configured to do so. Check with your telephone service provider or infrastructure maintainer whether it is necessary to warn users that emergency calls cannot be made from this telephone, and if so provide a suitable warning notice. A warning label, which can be fixed to the front of the telephone, is provided.

4.3. Titan

1. To prepare for installation, open the door (where fitted), then undo the four retaining screws to remove the faceplate from the rear enclosure. A 3mm Allen key is required. Do not remove the plastic cover on the back of the faceplate.

Caution – take care to support the spring-loaded door whilst open to prevent it slamming shut and trapping fingers.

2. All connections and option settings are on the rear of the faceplate towards the lower edge.

3. The Titan telephone is intended for vertical installation to a wall or pole. Select the required mounting method (section 5) and mount the rear enclosure first where applicable.
4. Route the required cables through glands as appropriate, and make connections and option settings following section 6.
5. Re-fit the faceplate ensuring a weatherproof seal
6. Test the operation of the telephone (section 3). Installation is now complete.

4.4. Commander

1. All connections and option settings are on the lower edge of the circuit board housed in the rear casing.
2. To prepare for installation, undo the three retaining screws shown to remove the front casing from the rear. The screws are captive in the front casing; a 5mm Allen key is required. Disconnect the handset / hookswitch connector(s) from the circuit board, noting the position and orientation.
3. The Commander telephone can be installed vertically to a wall or pole, or used horizontally on a desk. Select the required mounting method (section 5) and mount the rear casing first where applicable.
4. Route the required cables through glands as appropriate, and make connections and option settings following section 6.
5. Reconnect the handset / hookswitch. Re-secure the telephone Front Casing to the Rear Casing with the three retaining screws, ensuring a weatherproof seal.
6. Test the operation of the telephone (section 3). Installation is now complete.

5. Mounting methods and dimensions

5.1. General

IMPORTANT

Installation details differ between the TITAN and COMMANDER product ranges –please make sure you know which product you are installing and refer to the appropriate sections below.

Before mounting the telephone, check the cable routing and requirements. If glands are required, fit them to the case as follows:

1. Remove the RED blanking plug leaving the other (usually BLACK) in place.

Only fit a second gland if a separate cable is required to the phone (for example for an additional hook contact).

2. Select the appropriate sized gland:

Use the smaller gland for cables diameters 4 - 7mm.

Use the larger gland for cable diameters 8 - 13mm.

3. From the outside of the case, insert the selected gland into the threaded cable entry hole and tighten, so that its sealing washer is compressed against the enclosure surface.

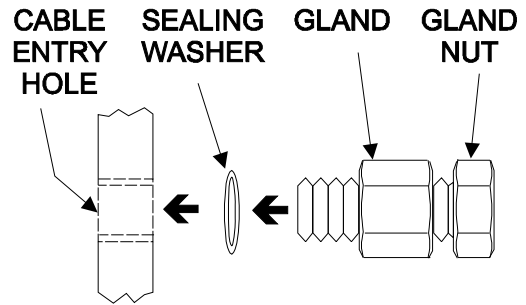

4. Proceed with chosen mounting method below

5.2. Titan

As standard, Titan with rear enclosure is supplied with 2 cable glands with sealing washers, 4 countersunk screws with wall plugs and a 3mm Allen key.

Titan telephones supplied for flush mounting have no rear enclosure – see section 5.2.3 below.

5.2.1 Wall mounting

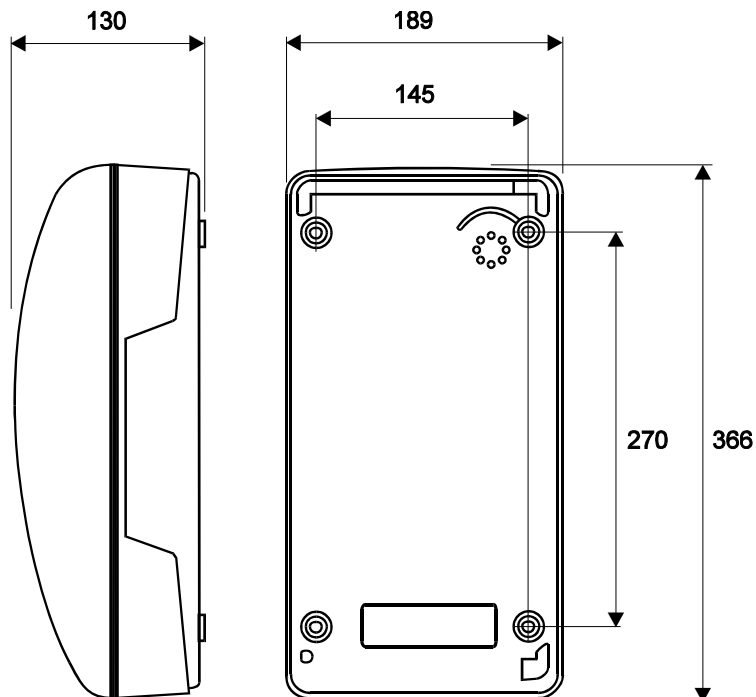

1. Using a suitable tool, punch out the 4 holes in the rear enclosure, taking care not to damage or dislodge the plastic bushes. Only four

of the eight holes are required - the outer ones are recommended. The inner holes are provided to be compatible with older-style mounting posts, and should be left intact if not used. If the inner holes are used they must be fitted with the supplied plastic bushes.

WARNING: *Your warranty will be invalidated if :-*

1. *Any fixing hole made in the rear enclosure is left unused.*
 2. *Any additional holes are drilled into the telephone enclosure.*
 3. *Plastic bushes are not used on all fixing holes.*
-

2. Mark the wall with hole centres based on the dimensions shown (145 x 270mm). If necessary offer the rear enclosure up to the wall to check alignment. Do not use the enclosure as a template for drilling.
 3. Drill holes in the wall on the marked positions. Select appropriate screws, wall plugs etc., for the type of wall, bearing in mind that the weight of the complete phone is around 5kg.
-

IMPORTANT: USE ONLY *countersunk-headed fixing screws. Check that screws seat properly in the plastic bushes to ensure a watertight seal. Do not use excessive tightening force, as this may crack the case.*

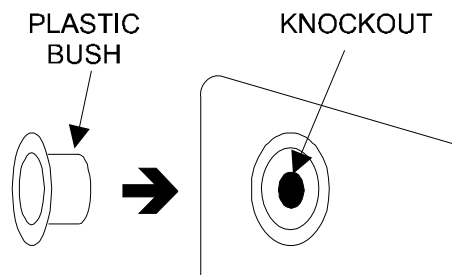

4. Ensure that all four plastic flanged bushes are in place and the rear enclosure is screwed tightly to the surface to prevent any water ingress through the punched holes.
5. Complete the installation by making the appropriate connections (section 6) and re-fitting the face plate.

5.2.2 Pole mounting

Kit No 100-02-0208-001

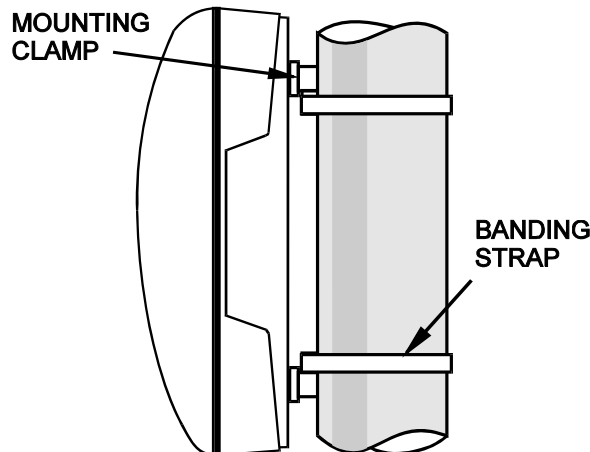

This accessory is for mounting GAI-Tronics telephones on to the side of round poles of 100mm to 200mm diameter, or on to square or rectangular section uprights of 100mm to 150mm across the mounting surface.

NOTE:

Banding straps (large scale worm-drive clamps) are not included in this kit and must be obtained separately. For details of where banding can be obtained, refer to GAI-Tronics.

1. After punching through the flanged bushes in the rear enclosure (as described in **WALL MOUNTING**), attach the pole mounting clamp assemblies to the rear enclosure using the M6 x 25 screws provided. Tighten to a torque of 4.5Nm max.
Note: only use the outer four holes, and ensure that the screws seat properly in the plastic bushes to avoid water ingress.
2. Ensuring that the glands are at the bottom, pass a proprietary banding strap round each of the pole mounting clamps and the support pole. Tighten securely.
3. Continue the installation by making the appropriate connections (section 6) and re-fitting the face plate.
4. Re-tighten the straps firmly and trim off any excess band material.
For security the driving head of the band may also be sawn off.

5.2.3 Flush mounting

Titan telephones supplied for flush mounting have a slightly different faceplate to those supplied with a rear enclosure – in particular the fixing holes are in different positions and there are no corner cut-outs (for door hinges). These models are usually described as “Titan fp” and the supplied mounting kit contains round-headed screws and no glands.

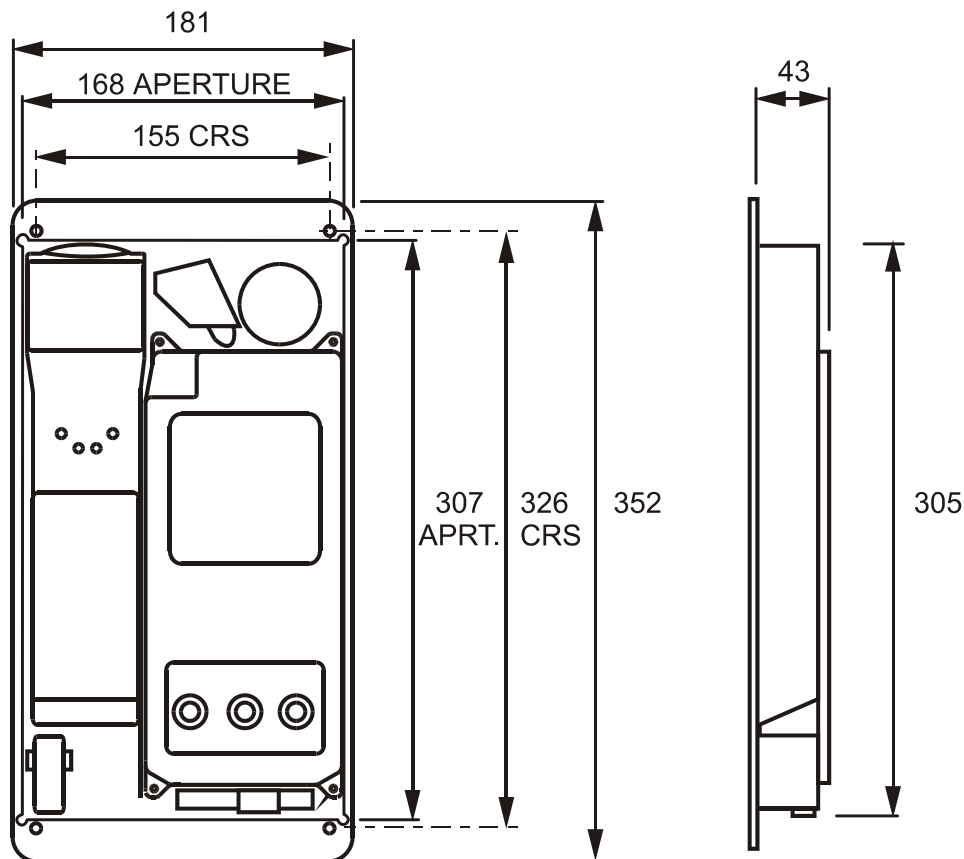

To flush-mount the telephone to a wall:

1. Prepare a recess (at least 50mm deep) in the wall according to the dimensions shown.
2. Mark the wall with hole centres based on the dimensions shown (155 x 326mm). If necessary offer the faceplate up to the wall to check alignment. Do not use the telephone as a template for drilling.
3. Drill holes in the wall at the marked positions. Select appropriate screws, wall plugs etc., for the type of wall, bearing in mind that the weight of the complete phone is around 1.5kg.
4. Route the cable to within the recess, and make connections to the telephone as shown in section 6.
5. Secure the telephone to the wall taking care not to trap any wires. Note that the gasket on the rear of the faceplate is intended to make a weather seal when compressed against a smooth surface. Do not rely on this gasket to keep water out if mounting directly to rough surfaces such as brickwork – in these cases use additional sealant around the edges to ensure a weatherproof seal.

5.3. Commander

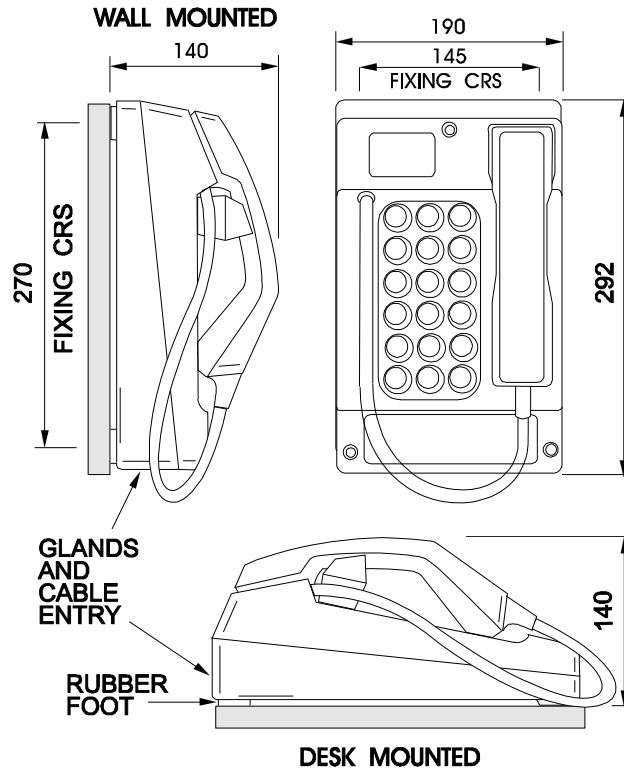

5.3.1 Wall mounting

To ensure weatherproof integrity when wall mounted, external cables should enter the enclosure from the bottom via the 20mm gland entries provided.

IMPORTANT:

Do not drill any extra holes as this will invalidate your warranty.

1. Remove rubber feet from the Rear Casing if fitted. Ensuring that the cable entries are at the bottom offer the Rear Casing up to the vertical surface and mark through the fixing holes. Do not use the Rear Casing as a template to drill the holes. Work only from the marked positions.
2. Drill the holes in the vertical surface to suit the best method of fixing.
3. Ensure the Rear Casing is securely attached to the vertical surface using the four 7mm diameter screw holes provided. No sealing washers are necessary.

IMPORTANT: *Do not use countersunk headed fixing screws. Only use round head, socket cap head or pan head screws. Take care not to over tighten the screws, doing so may damage the case and will invalidate your warranty.*

4. Continue the installation by making the appropriate connections (section 6).
5. Reconnect the handset / hookswitch. Secure the telephone Front Casing to the Rear Casing.

5.3.2 Pole mounting

Kit No 100-02-0208-001

This accessory is for mounting GAI-Tronics telephones on to the side of round poles of 100mm to 200mm diameter, or on to square or rectangular section uprights of 100mm to 150mm across the mounting surface. For flat mounting on surfaces greater than 150mm across use the desk or wall mounted methods as appropriate.

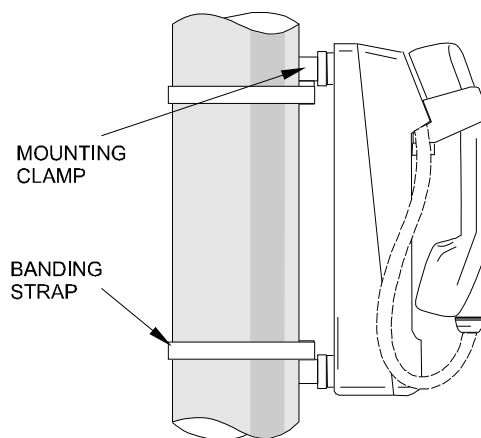

NOTE:

Banding straps (large scale worm-drive clamps) are not included in this kit and must be obtained separately. For details of where banding can be obtained, refer to GAI-Tronics.

1. Remove rubber feet from the Rear Casing if fitted. Attach the pole mounting clamp assemblies to the Rear Casing using the M6 x 25 screws provided. Tighten to a torque of 4.5Nm max.
2. Ensuring that the glands are at the bottom, pass a proprietary banding strap round each of the pole mounting clamps and the support pole. Tighten securely.
3. Continue the installation by making the appropriate connections (section 6).
4. Reconnect the handset / hookswitch. Secure the telephone Front Casing to the Rear Casing.
5. Re-tighten the straps firmly and trim off any excess band material. For security the driving head of the band may also be sawn off.

5.3.3 Desk mounting / Rake

For horizontal surfaces greater than 150 x 280mm use the free-standing desk mounted method below.

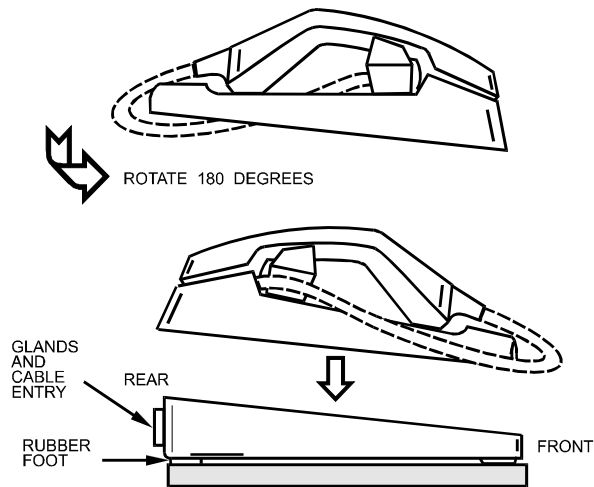

To provide a 'rake' for convenient operation, the Front Casing may be turned through 180° before it is fitted to the Rear Casing. Thus the cable entries are at the rear of the telephone.

1. Ensure that the supplied rubber feet are fitted to the underside of the Rear Casing.
2. Rotate the Front Casing through 180° taking care not to trap any wires.
3. Continue the installation by making the appropriate connections (section 6).
4. Reconnect the handset / hookswitch. Secure the telephone Front Casing to the Rear Casing.

6. Connections and option settings

If glands are used, insert the cable through the gland body and tighten the gland nut sufficiently to clamp the cable, making a seal. For Titan models with rear enclosure, ensure sufficient cable is left to allow removal of the faceplate without straining the cable.

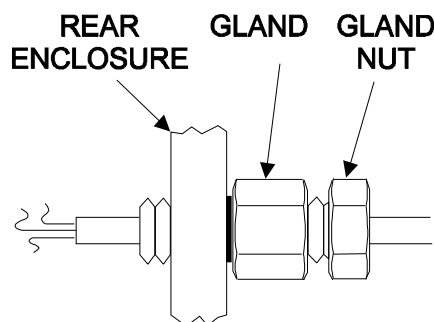

IMPORTANT: If only one gland entry is used, the blanking plug fitted to the second gland position must be left in place.

6.1. Standard connections and timer setting

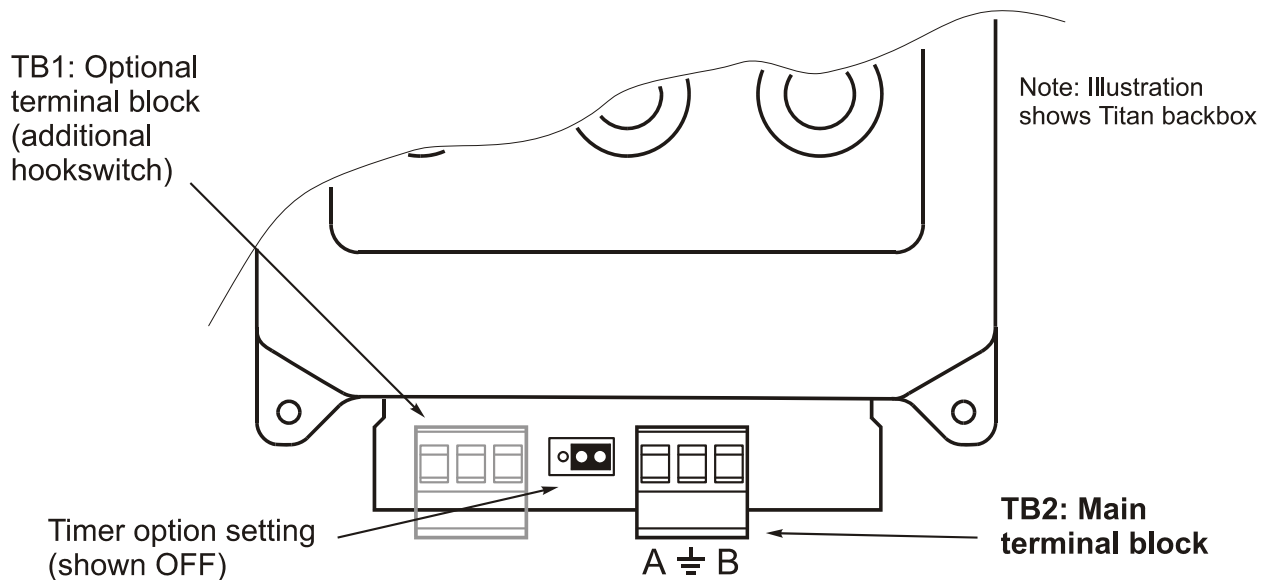

Connect the telephone line A and B to the main terminal block TB2 as shown.

The centre earth terminal is intended as an optional connection to a local earth for the purpose of enhanced protection from lightning transients, and is not required in terms of user safety from the telephone network.

Note: Conductor sizes to be 0.5mm-2.5mm² (flexible cable); 0.5-4.0mm² (solid cable) The terminal block can be disconnected from the circuit board for easier installation

Cabling must not infringe European Low Voltage Directive (LVD) 73/23/EEC.

The timer is set by the position of a two-way jumper plug on a three-pin header. Position the jumper to the left to set the timer **ON**, and to the right to set it **OFF**. Leaving the jumper unconnected will default to the timer being **OFF**.

This unit is supplied with the switch set to the **OFF** position.

6.2. Additional hook contact

Note – this optional connection is only available if specifically ordered. Contact GAI-Tronics for details.

The additional hook contact is provided on TB1. The diagram shows the state of the changeover contacts when the telephone is on hook. These contact labels are also on the PCB.

The switch is operated by the presence of the handset on the stowage. It is a voltage-free switch providing functional and basic insulation from the telephone network. It is intended to be connected to a TNV-3 or SELV circuit as defined by EN 60950-1:2001.

Switch maximum ratings (resistive load):

50 Vrms

100 VDC

300mA

3W

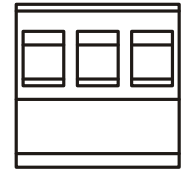

N/O C/O N/C

The circuit is not fused.

It is recommended that the switch cabling is routed via the spare gland in the case.

7. Aftercare

The purchase of your GAI-Tronics product does not end our commitment to you.

In addition to our warranty obligations, GAI-Tronics are able to offer various levels of maintenance packages, installation and commissioning packages and technical support, from ad-hoc repairs to full maintenance contracts.



By choosing GAI-Tronics as your aftercare provider you are ensured of manufacturer expertise and ISO 9000-certified quality control standards throughout the life of the product.

We can also supply a full range of accessories including mounting posts, beacons and high-volume sounders.

Contact GAI-Tronics for details. www.gai-tronics.co.uk

8. Technical Specifications

Operational Requirements	
Systems.	<ul style="list-style-type: none"> Analogue Public Switched Telephone Network (PSTN) Private Automatic Branch Exchange (PABX) Railway infrastructure concentrator.
Not suitable for connection to:	<ul style="list-style-type: none"> Payphone extensions Public Emergency Telephone System (PETS)
Telephone line parameters	<ul style="list-style-type: none"> Ring Voltage: 30V to 100V rms, 20Hz to 50Hz Line voltage 20 to 70 Vdc Loop current $\geq 15\text{mA}$
<p>Note: these telephones have been designed for pan-European single terminal connection to the PSTN. However, due to differences between the individual PSTNs & PABXs provided in different countries, this does not, of itself, give an unconditional assurance of successful operation on every PSTN or PABX termination point.</p>	
Product features	
Power supply	100% line power.
Hookswitch	Electronic with no external moving parts
Time Out	7 minutes (± 1). Selectable
Ringer loudness	80dBA @ 1m
Handset	<p>Suitable for inductive coupling to Hearing Aids having a 'T' switch position.</p> <p>Tested to ETS 300-381</p> 
Environmental limits	
Temperature:	<p>Operating: -20°C to +60°C</p> <p>Storing: -40°C to +70°C</p>
Relative Humidity	Up to 95% (non-condensing)
Ingress Protection	IP65. (Titan with door closed IP66) to EN60529:1992 – Degrees of protection provided by enclosures.
Physical characteristics	
Casing material	<p>Die-cast Aluminium (Titan)</p> <p>Glass reinforced polyester (Commander)</p>
Handset Material	Cycloy (2850) with stainless steel or polyester curled cord.
Weight	3 –5kg depending on option.
Dimensions	Dependant on model and variant. See 5.1 (Titan) or 5.3 (Commander)

Compliance to standards	
European Directive	1999/5/EC – European Radio & Telecommunications Terminal Equipment Directive (R&TTE). 
EMC	<p>EN55022:1998 – Information technology equipment. Radio disturbance characteristics.</p> <p>EN55024:1998 – Information technology equipment. Immunity characteristics.</p> <p>EN 50121-4: 2000 - Railway applications, emission and immunity</p> <p>RT/E/S/30003 iss1 1999 – The performance of Telecommunications Equipment under Conditions of Electrical Interference</p>
Safety	EN60950-1:2001 – Specification for information technology equipment, including electrical business equipment.
Telephony	<p>ETSI TBR21: Jan 1998</p> <p>ETSI TBR38: May 1998</p>
Lightning and transients	ITU-T recommendation K.21 (10/2000) - Enhanced surge protection.
Recycling Information	<p>The symbol shown here and on the product means that the product is classed as Electrical or Electronic Equipment and should not be disposed with other household or commercial waste at the end of its working life.</p> <p>The Waste of Electrical and Electronic Equipment (WEEE) Directive has been put in place to recycle products using best available recovery and recycling techniques to minimise the impact on the environment, treat any hazardous substances and avoid the increasing landfill.</p> <p>Business users should contact their suppliers and check the terms and conditions of the purchase contract and ensure that this product is not mixed with other commercial waste for disposal.</p> 

9. CE Declaration



Declaration of conformity

In accordance with European directive 1995/5/EC (R&TTE)

We, GAI-Tronics, a division of Hubbell Limited, of Brunel Drive, Stretton Park, Burton upon Trent, Staffordshire, England, DE13 0BZ, declare under our sole responsibility that the following product is in conformity with the directives and standards listed below and hold the relevant technical documentation at the above address.

Product description	Commander CB (1064) Titan CB (1064)
----------------------------	--

EC Directive	Standards applicable under the Directive
1999/5/EC Directive (R&TTE) European Radio & Telecommunications Terminal Equipment	EN 55022:1998 Information Technology Equipment (EMC) EN 55024:1998 Information Technology Equipment (EMC) EN 60950-1:2001 Information Technology Equipment Safety

Date of issue	Name/Title of authorised signatory	Signature of signatory
11 th March 2005	G.R. LINES BUSINESS UNIT MANAGER	

QC 300 / 8

GAI-TRONICS

A division of Hubbell Ltd.

Brunel Drive
Stretton Park
Burton on Trent
DE13 0BZ
England

Tel: 01283 500500

Fax: 01283 500400

www.gai-tronics.co.uk

The policy of GAI-Tronics is one of continuous improvement, therefore the Company reserves the right to change specifications without notice