

# Installation and User Guide

## Hands-free telephones

1090/1099 models

Vandal Resistant (VR) and Help Point

# GAI-TRONICS

# CONTENTS

1.	Safety and Care Information.....	3
2.	Product Description .....	3
2.1.	Changes from previous versions.....	4
3.	Operation / Testing .....	4
3.1.	Making a Call .....	4
3.2.	Answering calls .....	4
3.3.	Ending the Call.....	5
3.4.	Call timer .....	5
4.	SMART features .....	5
5.	Installation .....	5
5.1.	General .....	5
5.2.	Wall/Pole Mounting .....	6
5.3.	Flush mounting.....	9
6.	Connections .....	10
6.1.	Standard Connections.....	10
6.2.	Supplementary Power supply.....	10
6.3.	Optional relay outputs .....	11
6.4.	Optional external inputs.....	11
7.	Programming and Option Settings.....	12
7.1.	Quick Programming Guide (using a tone phone). .....	12
7.2.	Further programming options .....	13
7.3.	TMA.....	13
8.	Aftercare.....	14
9.	Technical Specifications .....	15
10.	CE Declaration .....	19

## 1. Safety and Care Information

- ▲ The safety of the user/installer relies on the isolation of the telephone network and not on the earthing of the case
- ▲ Please read these instructions thoroughly before starting installation. These products must be installed by competent personnel familiar with telephone installation.
- ▲ Telephone network voltages can be hazardous. Take adequate precautions when opening the case or installing. If in doubt, disconnect the telephone line elsewhere before accessing the line connections.
- ▲ For increased protection against lightning transients, attach a local earth to the main terminal block (see section 6.1)

## 2. Product Description

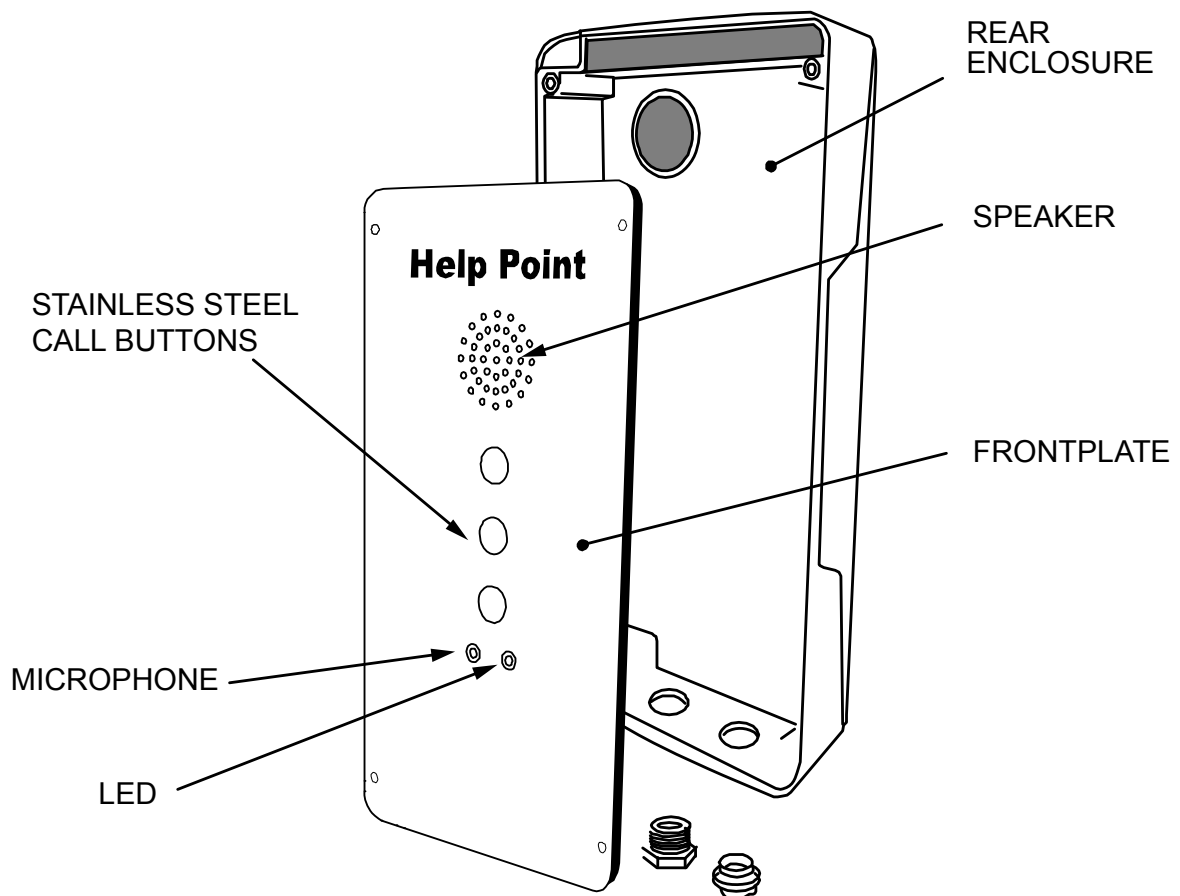

This manual describes Help Point and VR (Vandal Resistant) ranges of hands-free telephone products. These units offer high degrees of resistance to weather and abuse, having only a microphone, speaker and one or more metal buttons mounted on a flat, metal faceplate, in place of a traditional handset and keypad. Main features include:

- 4mm thick aluminium faceplate
- Waterproof speaker, protected by stainless steel mesh

- Sensitive microphone, protected by semi porous membrane and aluminium grille
- Stainless steel auto-dial button(s)
- Call status LED
- Auto-dial numbers are remotely programmable
- Line powered operation (optional supplementary power supply available)
- Optional cast aluminium rear enclosure
- Optional induction loop for the hearing impaired.
- Optional isolated input for power supply
- Optional relay outputs (2)
- Optional logic inputs (4)

### **2.1. Changes from previous versions**

This manual describes an updated range of products introduced in December 2007. For those familiar with GAI-Tronics' products, the list of new or changed features is as follows:

- New terminal layout (section 6).
- Increased lightning protection (section 9).
- Compliance with railway EMC standards (section 9)
- Optional additional relay outputs and logic inputs (section 6.3 & 6.4)
- Optional isolated input for power supply (section 6.2)
- Improved clear-down mechanisms (section 3.3)
- RoHS compliant

For the full list of product features, please see the specifications in section 9.

## **3. Operation / Testing**

### **3.1. Making a Call**

To make a call, press the required button and wait for connection. The unit will seize the line and then automatically dial the pre-programmed number.

### **3.2. Answering calls**

To receive a call, press any button when ringing is heard.

### 3.3. Ending the Call

There is no direct way for a user to end a call from the unit. The unit will close down and release the line on receipt of the following signals, usually when the remote party clears:

- Line polarity reversal
- A line break (sometimes referred to as a “k break”).
- Receipt of exchange call progress tones (see section 9 for specification)

### 3.4. Call timer

The phone has a programmable call timer that can limit the maximum call duration.

When ON, the timer forces the phone back off line after the preset time. This prevents the line remaining tied if the neither party ends the call. The timer is factory-set to 7mins by default, but can be set to any value (up to 2¾hrs) or disabled. See section 7.2.1.

## 4. SMART features

This family of products has a wide range of intelligent features including:

- Monitoring of faults and health status
- Remote programming of auto-dial numbers and configuration parameters
- Alternate day / night autodial numbers
- Call logs for calls made to and from the telephones

These features are all available over standard, 2 wire telephone lines with no external power required at the phone.

To use these features, GAI-Tronics provide a Telephone Management Application (TMA) available separately, see section 7.3.

## 5. Installation

### 5.1. General

#### **IMPORTANT**

---

**All possible measures must be taken to ensure water, fluid or dust does not contaminate the internal components of the telephone whilst unpacking, preparing and installing the telephone in inclement weather conditions or by negligence.**

**Failure to do so may invalidate your warranty.**

---

These telephones are supplied without connection leads – cabling to the telephone network must be supplied and installed by the installer. Because of this, extra precautions must be observed: installers must ensure that they have the permission of the owner of the PABX or telephone network to which the telephone is to be connected, and that installation is carried out by

competent personnel. Where the telephone faceplate is mounted into an enclosure or recess other than the standard GAI-Tronics backbox, then additional care must be taken that wiring and proximity to conducting surfaces complies with the requirements of the R&TTE Directive - 1999/5/EC.

Contact GAI-Tronics if installation service is required.

From a mounting and installation point of view, VR and Help Point products are identical.

## 5.2. Wall/Pole Mounting

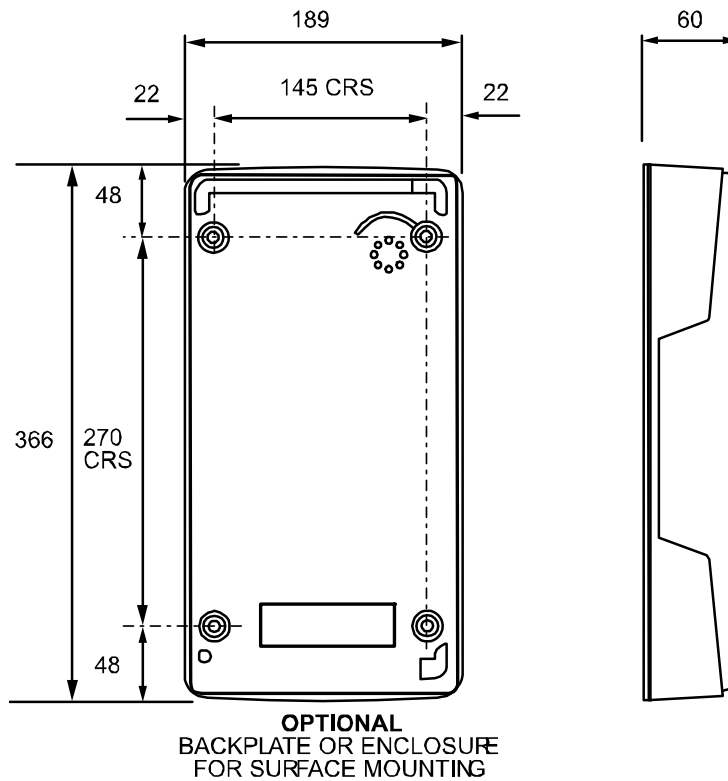

When wall or pole mounted, VR and Help Point units must be fitted inside a dedicated rear enclosure.

Before mounting the telephone, check the cable routing and requirements. If glands are required, fit them to the case as follows:

1. Remove the RED blanking plug leaving the other (usually BLACK) in place.  
Only fit a second gland if a separate cable is required to the phone (for example for an additional hook contact).
2. Select the appropriate sized gland:  
Use the smaller gland for cables diameters 4 - 7mm.  
Use the larger gland for cable diameters 8 - 13mm.
3. From the outside of the case, insert the selected gland into the threaded

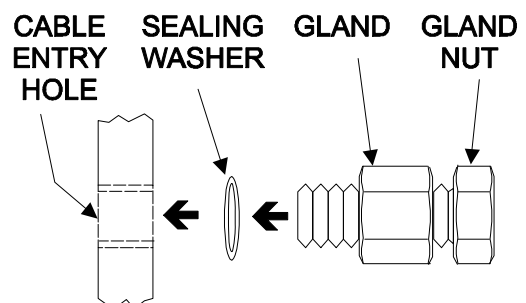

cable entry hole and tighten, so that its sealing washer is compressed against the enclosure surface.

4. Proceed with chosen mounting method below

### 5.2.1 Wall mounting

1. Using a suitable tool, punch out the 4 holes in the rear enclosure, taking care not to damage or dislodge the plastic bushes. Only four of the eight holes are required - the outer ones are recommended. The inner holes are provided to be compatible with older-style mounting posts, and should be left intact if not used. If the inner holes are used they must be fitted with the supplied plastic bushes.

---

**WARNING:** *An unsafe condition could occur (and your warranty will be invalidated) if :-*

1. *Any fixing hole made in the rear enclosure is left unused.*
  2. *Any additional holes are drilled into the telephone enclosure.*
  3. *Plastic bushes are not used on all fixing holes.*
- 

2. Mark the wall with hole centres based on the dimensions shown (145 x 270mm). If necessary offer the rear enclosure up to the wall to check alignment. Do not use the enclosure as a template for drilling.
3. Drill holes in the wall on the marked positions. Select appropriate screws, wall plugs etc., for the type of wall, bearing in mind that the weight of the complete phone is around 5kg.

---

**IMPORTANT:** *USE ONLY countersunk-headed fixing screws. Check that screws seat properly in the plastic bushes to ensure a watertight seal. Do not use excessive tightening force, as this may crack the case.*

---

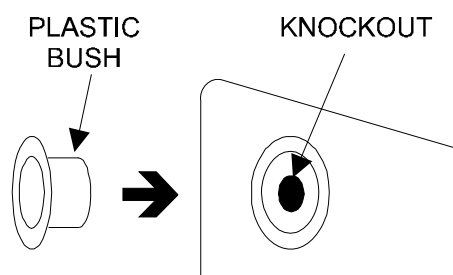

4. Ensure that all four plastic flanged bushes are in place and the rear enclosure is screwed tightly to the surface to prevent any water ingress through the punched holes.
5. Complete the installation by making the appropriate connections (section 6) and re-fitting the face plate.

## 5.2.2 Pole mounting

Kit No 100-02-0208-001

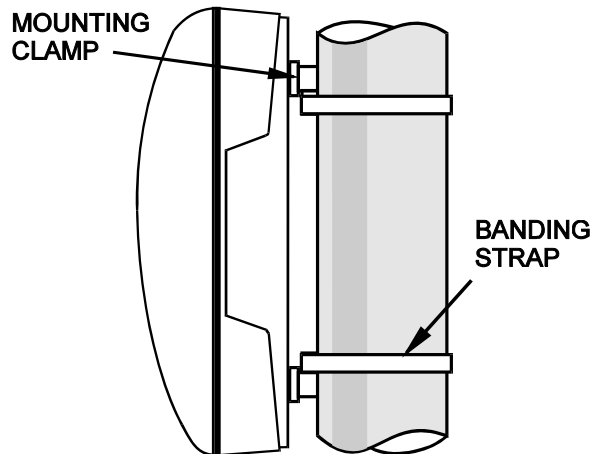

This accessory is for mounting GAI-Tronics telephones on to the side of round poles of 100mm to 200mm diameter, or on to square or rectangular section uprights of 100mm to 150mm across the mounting surface.

### NOTE:

---

*Banding straps (large scale worm-drive clamps) are not included in this kit and must be obtained separately. For details of where banding can be obtained, refer to GAI-Tronics.*

---

1. After punching through the flanged bushes in the rear enclosure (as described in **WALL MOUNTING**), attach the pole mounting clamp assemblies to the rear enclosure using the M6 x 25 screws provided. Tighten to a torque of 4.5Nm max.  
Note: only use the outer four holes, and ensure that the screws seat properly in the plastic bushes to avoid water ingress.
2. Ensuring that the glands are at the bottom, pass a proprietary banding strap round each of the pole mounting clamps and the support pole. Tighten securely.
3. Continue the installation by making the appropriate connections (section 6) and re-fitting the face plate.
4. Re-tighten the straps firmly and trim off any excess band material. For security the driving head of the band may also be sawn off.

### 5.3. Flush mounting

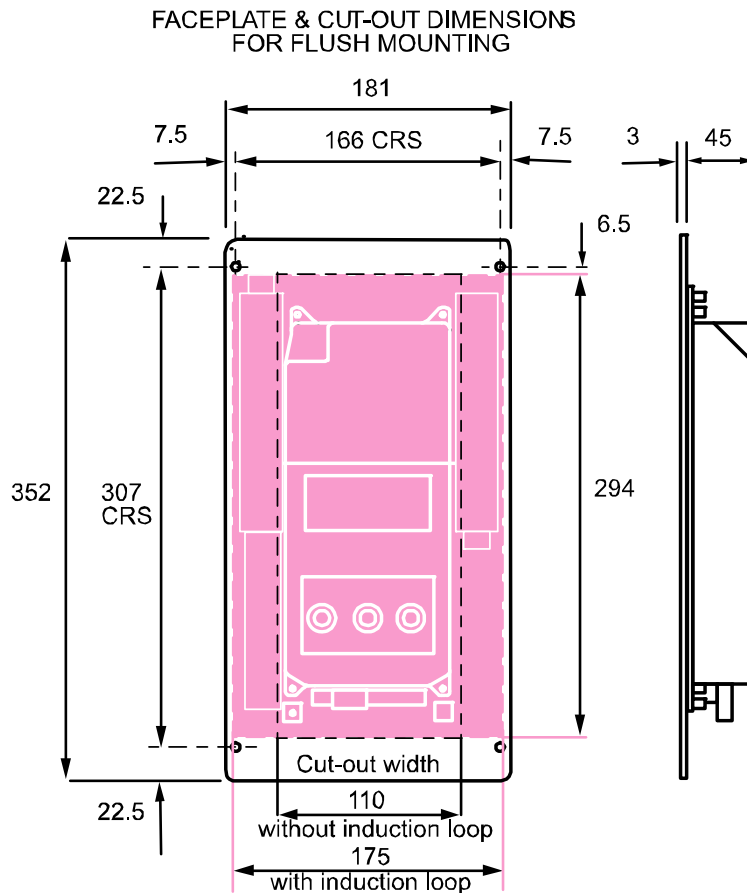

To flush-mount the telephone to a wall:

1. Prepare a recess (at least 50mm deep) in the wall according to the dimensions shown.
2. Mark the wall with hole centres based on the dimensions shown (155 x 326mm). If necessary offer the faceplate up to the wall to check alignment. Do not use the telephone as a template for drilling.
3. Drill holes in the wall at the marked positions. Select appropriate screws, wall plugs etc., for the type of wall, bearing in mind that the weight of the complete phone is around 1.5kg.
4. Route the cable to within the recess, and make connections to the telephone as shown in section 6.

Secure the telephone to the wall taking care not to trap any wires. Note that the gasket on the rear of the faceplate is intended to make a weather seal when compressed against a smooth surface. Do not rely on this gasket to keep water out if mounting directly to rough surfaces such as brickwork – in these cases use additional sealant around the edges to ensure a weatherproof seal.

## 6. Connections

### 6.1. Standard Connections

Connect the telephone line A and B to the main terminal block CON1 as shown.

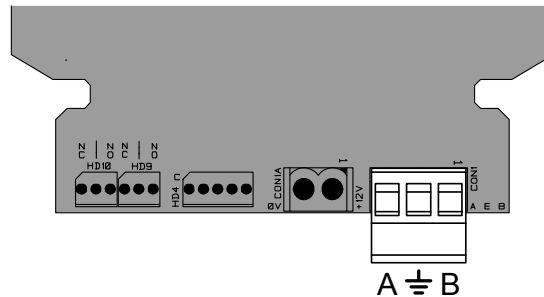

The centre earth terminal is intended as an optional connection to a local earth for the purpose of enhanced protection from lightning transients, and is not required in terms of user safety from the telephone network.

---

**Note:** Conductor sizes to be 0.5mm-2.5mm<sup>2</sup> (flexible cable); 0.5-4.0mm<sup>2</sup> (solid cable) The terminal block can be disconnected from the circuit board for easier installation

---

*Cabling must not infringe European Low Voltage Directive (LVD) 73/23/EEC.*

---

### 6.2. Supplementary Power supply

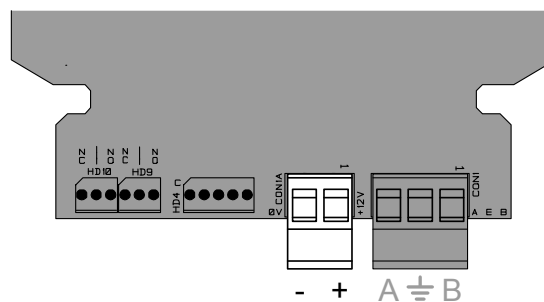

GAI-Tronics hands-free telephones can be equipped with a supplementary power supply, required to power the induction loop (if fitted), external relays (if fitted) and generally to provide increased audio output level.

The standard telephone does not require this supplementary supply for normal operation, but note that ringing on exchanges with low ring voltages (<40Vac) may be unreliable without a supplementary supply.

The supplementary power input is provided on CON1A as shown and must be an earth-free isolated supply of 12V dc (250mA min) to suit the power requirements of the required peripherals, suitable for connection to a TNV-3 circuit.

**Note:** A common supply cannot be used for multiple telephones unless the unit is equipped with an isolated power supply input. This is available as an option if specifically ordered. Contact GAI-Tronics for details.

### 6.3. Optional relay outputs

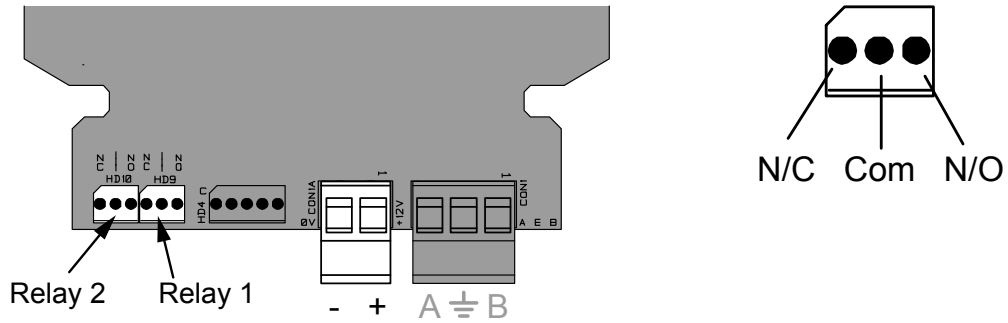

GAI-Tronics hands-free telephones can be equipped with external relay outputs, controlled by the telephone software. Note – these optional connections are only available if specifically ordered, and a supplementary power supply (see section 6.2) is required. Contact GAI-Tronics for details.

The additional outputs are provided on HD9 & HD10 as shown and are isolated SELV outputs as defined by EN 60950-1:2001.

**To comply, the installer must ensure that any connections are within SELV limits.**

Relay ratings / SELV limits: 30Vdc, 42.4V peak (resistive load)

Max switching current: 3A

### 6.4. Optional external inputs

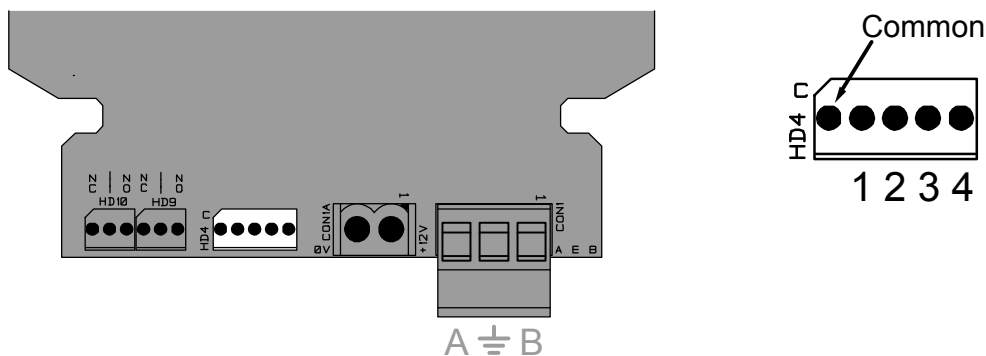

GAI-Tronics hands-free telephones can be equipped with 4 external inputs, which can be used to generate call-in events or alarm reports (using TMA). Note – these optional connections are only available if specifically ordered. Contact GAI-Tronics for details.

The inputs are provided on HD4 as shown, and are also labelled on the circuit board. Control inputs are for connection to voltage free contacts only. Internal pull-up resistor source current = 33µA. These inputs form part of a TNV3 circuit and precautions must be taken to prevent hazardous voltages being applied to these circuits.

NB these inputs are not isolated from the telephone network.

## 7. Programming and Option Settings

Programming and option setting is done remotely by sending commands down the telephone line to the unit. This can be done by either using a tone phone, or by using GAI-Tronics TMA - a PC software application.

### 7.1. Quick Programming Guide (using a tone phone).

Autodial memory numbers can be programmed remotely using a tone dialling (DTMF) telephone. The procedure is as follows:

- 1) Lift the handset of the tone dialling telephone.
- 2) Dial the number of the telephone to be programmed.
- 3) Listen for the ringing tone in the handset earpiece.
- 4) After 4-5 rings a beep will be heard, immediately after the beep press the star key three times. Note the number of rings before the beep is heard is user configurable, this may be set between 0 and 15 rings before the beep is sent.
- 5) The SMART telephone should now stop ringing. Pause for 3 seconds.
- 6) Enter the factory preset PIN Number (\*\*0000). Pause for 3 seconds.
- 7) To program Memory 1, Press \*101 followed by your required number for the first Memory Button then hash (#) to complete. The smart phone should confirm acceptance with a 'beep'.
- 8) For Memory 2 follow the same procedure, but this time begin with \*102, followed by your required number for the second Memory Button then hash (#) to complete. Wait for the confirmation tone.
- 9) Continue this procedure for all remaining Memory buttons, as required.
- 10) When programming is complete, Press \*99 to activate remote 'Hang-up' function.

#### Example:

Programming requirement	Command Digits
Program Memory 2 with 01234 567890	*102 01234567890#

#### Trouble Shooting

The SMART Telephone should only return a 'beep' after a Programming command has been sent. If the SMART phone 'beeps' *during* Command entry, then you should try the following:

- 1) Problems may occur when the SMART phone is unable to distinguish between the different command strings and that's why it's important to pause after the initial entry of the "\*\*\*" command. Also make sure that you are leaving a three-second gap after entering the default PIN code. If this is not the case, then you should begin the above programming procedure again. (Starting at 5)

- 2) Has the default PIN code already been changed by another user? Check your own records and enter the correct PIN code as necessary. Note that this problem can only occur if you are carrying out a re-programming exercise. Telephones always leave the factory with the value \*\*0000 set as default.
- 3) After entering the PIN code you can check that it has been received and understood by the SMART Telephone –Wait three seconds and enter the command \*20. If all is ok then you will here a string of 6 DTMF tones in the handset earpiece of your tone dialling phone. You can now assume that it's ok to continue with your required programming (Starting at 8)

## **7.2. Further programming options**

In addition to programming auto-dial numbers, several other features can be programmed using a tone-phone.

### **7.2.1 Time-out**

The call time out is factory set to 7 minutes, meaning that the phone will drop the call and go back on hook electronically after this period even if a call is in progress. This feature is provided to guard against the handset being left off hook and tying up the line.

The timer can be set in increments of 10s from 60s to 9980s by entering the code \*50, followed by the required timeout divided by 10s, followed by #.

For example to set the timer to 3 minutes enter \*50 18 # (3min is 180s, 18 is 180/10).

This command must be entered between entering the PIN and closing the phone down with \*99.

To disable the timer use a value of 999, ie \*50 999 #.

The phone will respond to a successful command with a single tone.

### **7.2.2 Inserting a pause into an auto-dial number**

To enter a pause (approx 1 second gap) into a dial number, use the digits \*1.

For example to program 9 <pause> 12345 into memory 1, use

\*101 9 \*1 12345 #

## **7.3. TMA**

GAI-Tronics TMA is a fully featured software application (Telephone Management Application) for Windows™ XP, offering the facilities to program, maintain, monitor and report on all types of GAI-Tronics SMART products.

Full details on the configuration and use of TMA are provided with the package itself.

Contact GAI-Tronics for further details.

**TMA part numbers:**

TMA package (UK): 100-02-0309-001

TMA package (Europe): 100-02-0309-002

Each package includes the TMA software (including comprehensive help documentation and installation instructions), external modem and dongle.

## **8. Aftercare**

The purchase of your GAI-Tronics product does not end our commitment to you.

In addition to our warranty obligations, GAI-Tronics are able to offer various levels of maintenance packages, installation and commissioning packages and technical support, from ad-hoc repairs to full maintenance contracts.

By choosing GAI-Tronics as your aftercare provider you are ensured of manufacturer expertise and ISO 9000-certified quality control standards throughout the life of the product.

We can also supply a full range of accessories including mounting posts, beacons and high-volume sounders.

Contact GAI-Tronics for details. [www.gai-tronics.co.uk](http://www.gai-tronics.co.uk)

## 9. Technical Specifications

<b>Operational Requirements</b>	
Systems.	<ul style="list-style-type: none"> <li>Analogue Public Switched Telephone Network (PSTN)</li> <li>Private Automatic Branch Exchange (PABX)</li> </ul>
Not suitable for connection to:	<ul style="list-style-type: none"> <li>Payphone extensions</li> <li>Public Emergency Telephone System (PETS)</li> </ul>
Telephone line parameters (without supplementary power supply)	<ul style="list-style-type: none"> <li>Ring Voltage: 40V to 100V rms, 20Hz to 50Hz</li> <li>Line voltage 20 to 70 Vdc</li> <li>Loop current <math>\geq 25\text{mA}</math></li> </ul>
With supplementary power supply	<ul style="list-style-type: none"> <li>Ring Voltages down to 30V</li> <li>Loop current down to 15mA</li> </ul>
<p><b>Note:</b> these telephones have been designed for pan-European single terminal connection to the PSTN. However, due to differences between the individual PSTNs &amp; PABXs provided in different countries, this does not, of itself, give an unconditional assurance of successful operation on every PSTN or PABX termination point.</p>	
<b>Product features</b>	
Power supply	<ul style="list-style-type: none"> <li>Can operate from line power only.</li> <li>Supplementary power supply input (non-isolated) provided as standard. 12Vdc (<math>\pm 1</math>) @ 250mA min.</li> <li>Supplementary power will enhance ringing and audio quality.</li> <li>Supplementary power is required for induction loop and external relay options.</li> <li>Isolated power supply input is available as an option</li> </ul>
Hookswitch	Electronic with no external moving parts
Ringer loudness	80dBA @ 1m
Call termination	<p>Calls started from the hands-free telephone can terminate in one of three ways:</p> <ul style="list-style-type: none"> <li>Polarity reversal of DC feed</li> <li>K-break (interruption of loop current <math>&gt; 50\text{ms}</math>)</li> <li>Call progress tone: a tone received on the line, in the frequency range 280 – 550Hz, either: <ul style="list-style-type: none"> <li>A continuous tone for 5s, or</li> <li>A repeated tone (“beep”) for 5 identical repetitions.</li> </ul> </li> </ul>

Induction loop (optional)	Suitable for inductive coupling to Hearing Aids having a 'T' switch position. Supplementary power required.	
Dialling and recall mode	MF only. TBR only.	
Monitored faults and sensors	<ul style="list-style-type: none"> <li>• Hookswitch</li> <li>• Brown out (power failure)</li> <li>• Call log full</li> <li>• 4 auxilliary inputs (optional)</li> </ul>	
Parameters configurable with TMA	<ul style="list-style-type: none"> <li>• Autodial numbers - including time-switched alternate numbers</li> <li>• Speech receive level.</li> <li>• Rings before / after auto-answer</li> <li>• Time out (default 7 minutes)</li> <li>• Mute before dial</li> <li>• DTMF detection window</li> </ul>	
Monitoring method	<ul style="list-style-type: none"> <li>• Remote polling (initiated by TMA)</li> <li>• Call-in (initiated by the telephone at a preset time)</li> </ul>	

<b>Environmental limits</b>	
Temperature:	Operating: -20°C to +60°C Storing: -40°C to +70°C
Relative Humidity	Up to 95% (non-condensing)
Ingress Protection	IP65 (from the front only unless fitted in the GAI-Tronics rear enclosure) to EN60529:1992 – Degrees of protection provided by enclosures.
<b>Physical characteristics</b>	
Faceplate / rear enclosure material	Aluminium. Powder coated.
Weight	2kg without rear enclosure 4kg with rear enclosure
Dimensions	181W x 352H x 45D without rear enclosure 189W x 366H x 60D with rear enclosure See section 5

<p>Recycling information</p>	<p>The symbol shown here and on the product means that the product is classed as Electrical or Electronic Equipment and should not be disposed with other household or commercial waste at the end of its working life.</p> <p>The Waste of Electrical and Electronic Equipment (WEEE) Directive has been put in place to recycle products using best available recovery and recycling techniques to minimise the impact on the environment, treat any hazardous substances and avoid the increasing landfill.</p> <p>Business users should contact their suppliers and check the terms and conditions of the purchase contract and ensure that this product is not mixed with other commercial waste for disposal.</p>	
------------------------------	---	---

<b>Compliance to standards</b>	
European Directives	<p>1999/5/EC – European Radio &amp; Telecommunications Terminal Equipment Directive.</p> <p>2002/96/EC - Waste Electrical and Electronic Equipment (WEEE) Directive</p> <p>2002/95/EC - Restriction of the use of certain hazardous substances in electrical and electronic equipment (RoHS)</p> 
EMC	<p>EN55022:2006 – Information technology equipment. Radio disturbance characteristics.</p> <p>EN55024:1998 (+A1:2001 + A2:2003) – Information technology equipment. Immunity characteristics.</p> <p>EN 50121-4: 2006 - Railway applications, emission and immunity</p> <p>RT/E/S/30003 iss1 1999 – The performance of Telecommunications Equipment under Conditions of Electrical Interference</p>
Safety	<p>EN60950-1:2001 (+A11:2004) – Specification for information technology equipment, including electrical business equipment.</p> <p>BS6789 Pt.2:1984 (Clause 7.5) – Acoustic Shock. Apparatus with loudspeaking facilities for connection to U.K public switched telephone networks.</p> <p>EN50371:2002 - Generic standard to demonstrate the compliance of low power electronic and electrical apparatus with the basic restrictions related to human exposure to electromagnetic fields (10 MHz - 300 GHz). General public.</p>
Telephony	<p>ES 203 021 - Access and Terminals (AT); Harmonized basic attachment requirements for Terminals for connection to analogue interfaces of the Telephone Networks.</p> <p>EN 301 437 - Terminal Equipment (TE) - Attachment requirements for pan-European approval for connection to the analogue Public Switched Telephone</p> <p>ES 201 729 - Public Switched Telephone Network (PSTN) - 2-wire analogue voice band switched interfaces; - Timed break recall (register recall); - Specific requirements for terminals</p> <p>BS6789 Pt.2:1984 – Apparatus with loudspeaking facilities for connection to U.K public switched telephone networks.</p>
Lightning and transients	<p>ITU-T recommendation K.21 (07/2003) - Enhanced surge protection.</p>

## 10. CE Declaration

### GAI-Tronics

A Division of Hubbell Ltd

## Declaration of Conformity

We, GAI-Tronics (a division of Hubbell Ltd.), of Brunel Drive, Stretton Business Park, Burton upon Trent, Staffordshire, England, DE13 0BZ, declare under our sole responsibility, that the following product is in conformity with the directives and standards listed below and hold the relevant technical documentation at the above address.

<b>Product description</b>	Hands-free telephones, 1090/1099 models
----------------------------	---

EC Directive	Standards applicable under the Directive
1999/5/EC – European Radio & Telecommunications Terminal Equipment Directive.	<p><b>EMC</b></p> <p>EN55022:2006 – Information technology equipment. Radio disturbance characteristics.</p> <p>EN55024:1998 (+A1:2001 + A2:2003) – Information technology equipment. Immunity characteristics.</p>
	<p><b>Safety</b></p> <p>EN60950-1:2001 (+A11:2004) – Specification for information technology equipment, including electrical business equipment.</p> <p>EN50371:2002 - Generic standard to demonstrate the compliance of low power electronic and electrical apparatus with the basic restrictions related to human exposure to electromagnetic fields (10 MHz - 300 GHz). General public.</p>
2002/95/EC - Restriction of the use of certain hazardous substances in electrical and electronic equipment (RoHS)	

Date of issue	Name of authorised signatory	Signature of signatory
30/11/2007	G Lines Business Unit General Manager	

## **GAI-TRONICS**

A division of Hubbell Ltd.

Brunel Drive  
Stretton Park  
Burton on Trent  
DE13 0BZ  
England

Tel: 01283 500500

Fax: 01283 500400

[www.gai-tronics.co.uk](http://www.gai-tronics.co.uk)

The policy of GAI-Tronics is one of continuous improvement, therefore the Company reserves the right to change specifications without notice