

Installation and User Guide

Auteldac 4 VoIP

ATEX / IECEx Approved
Hazardous Area Telephone

IMPORTANT

**THIS PRODUCT MUST BE CONFIGURED PRIOR
TO INSTALLATION**

PLEASE READ THIS GUIDE FIRST

GAI-TRONICS

A Division of Hubbell Ltd

CONTENTS

1	SAFETY INFORMATION.....	2
2	PRODUCT DESCRIPTION.....	3
3	FEATURES.....	4
4	INSTALLATION.....	5
4.1	Sequence of Events.....	5
4.2	Pre-installation.....	5
4.3	Dimensions.....	7
4.4	Preparation.....	8
4.5	Mounting Methods.....	9
4.6	Connections and Cabling.....	12
4.7	Option Settings, Configuration and Programming.....	18
4.8	Assembly of Telephone on to Installed Base.....	18
5	OPERATION.....	20
5.1	Making and Receiving Calls.....	20
5.2	Last Number Redial.....	21
5.3	Recall Function.....	21
5.4	Secrecy or Mute Function.....	21
5.5	Headset Operation.....	22
6	MAINTENANCE.....	23
6.1	Procedures.....	23
6.2	Fault Finding & Field Repairs.....	23
6.3	Possible Operating Faults.....	24
7	TECHNICAL SPECIFICATIONS.....	25
7.1	Suitability for Use.....	25
7.2	Product Features.....	25
7.3	Headset.....	26
7.4	Physical Characteristics.....	27
7.5	Environmental Considerations.....	27
7.6	Related Standards and Regulations.....	27
7.7	Recycling Information.....	30
8	ATEX certificate.....	31
9	IECEX certificate.....	34
10	CE DECLARATION.....	37
11	Licensing Notices.....	38

1 SAFETY INFORMATION

- ▲ **IMPORTANT:**
ALL POSSIBLE MEASURES MUST BE TAKEN TO ENSURE WATER, FLUID OR DUST DOES NOT CONTAMINATE THE INTERNAL COMPONENTS OF THIS TELEPHONE WHILST UNPACKING, PREPARING OR INSTALLING IT, OR BY NEGLIGENCE.
FAILURE TO OBSERVE THIS PRECAUTION WILL INVALIDATE CERTIFICATION AND YOUR WARRANTY
- ▲ **Please read these instructions thoroughly before starting installation. These products must be installed by competent personnel familiar with electrical and network installations, as well as the hazardous area regulations.**
- ▲ **The case must not be opened in the hazardous area unless all connections are isolated outside the hazardous area.**
- ▲ **This product must be configured prior to installation. See section 4.2.1 for details**
- ▲ **Some versions of this product are supplied with long handset or headset cables, which could present a trip hazard.** Therefore care must be taken when using the handset/headset at extended distances, so that personnel or equipment in the vicinity are not impeded, trapped or entangled by the cord. Also, care must be taken to stow these long cord handset/headsets so they do not pose an entanglement or tripping hazard.
- ▲ **Noise level hazard.** The telephone ringer can develop a sound level in excess of 90dBA @ 1 metre. Therefore, it is the installer's responsibility to take the necessary measure to comply with the European directive 2003/10/EC regarding the exposure of workers to the risks arising from physical agents (noise).

2 PRODUCT DESCRIPTION

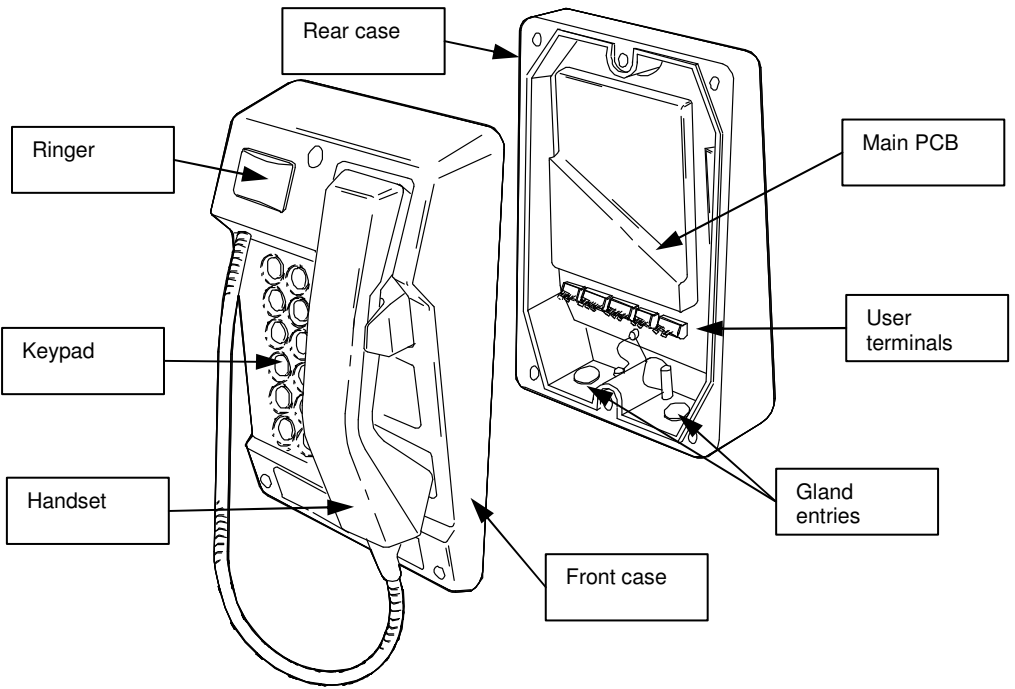

Auteldac 4 VoIP Hazardous Area Telephone at a glance

3 FEATURES

This manual describes the voice over internet protocol (VoIP) versions of the Auteldac 4. Auteldac 4 VoIP is an Ex certified telephone built to withstand arduous industrial atmospheres and environmental extremes. Features include:

- ATEX / IEC Ex certified for safe operation in hazardous areas
- Carbon loaded glass filled polyester body - rugged and corrosion free.
- Weather resistant up to IP66
- Rugged handset with curly cord or armoured stainless steel cord.
- Hearing aid compatible inductive coupling as standard
- Headset option available.
- Integral 90dBA ringer with volume adjustment.
- Programmable, volt-free contact output
- Available in 18 button and zero button (hotdial) versions
- One touch dial memories (18 button version only)
- SIP compatible (RFC3261)
- Automatic outgoing call diversion (memory list)
- Real-time alarm reporting via email or Syslog
- Power over Ethernet 802.3af compatible (spare pair only)
- Configurable via web page or download

4 INSTALLATION

Please read all these instructions thoroughly before starting installation.

THESE UNITS MUST BE CONFIGURED BEFORE THEY ARE INSTALLED.

All GAI-Tronics VoIP telephones have identical settings as factory defaults, so each one must be individually configured to give it a unique identity on the network. This may be difficult to do after the units are installed.

4.1 Sequence of Events

In order to ensure the installation is as trouble free as possible, please follow the recommended sequence of events described in detail in the sections below. In summary this sequence is:

- Pre installation – preparations to make before installation, including initial configuration.
- Mounting – physically fixing the unit in place
- Connection – attach cables
- Testing – ensure it functions as expected
- Put into service – finalise the installation

4.2 Pre-installation

Please ensure that each unit is configured prior to installation, and that the requirements listed below are taken into consideration before installation begins:

4.2.1 Initial Configuration

As factory default, each Auteldac 4 VoIP has the following settings:

- Static IP address **192.168.1.2**
- Log in user name: **user**
- Log in password: **password**

As an absolute minimum, you will need to either assign a unique static IP address to each unit or set it to DHCP.

If using DHCP please note that each unit already has a unique host name (factory set to the unit's serial number).

To make these changes, log in to the phone's web pages using the details above.

You will need to power the unit (using DC power or PoE) and to connect it to a network. See section 4.6.2.

You will also need the Configuration guide, available from:

www.gai-tronics.co.uk/voipsupport.htm

Note there is also a link to this support page on the phone's home page. The configuration guide explains all the configuration settings in detail.

IMPORTANT WARNING

Please ensure when changing the IP address, user name or password, that the new details are recorded and securely kept. If these details are lost it will not be possible to access the unit's configuration web pages. If this occurs the unit will need to be returned to factory for reset.

4.2.2 Requirements before installation

Before installing the unit, please ensure that the following are available:

- **Pre configuration.** It is essential that each phone is pre-configured before installation, see section 4.2.1 above.
- **Power.** Ensure that there is a suitable means of providing power to the phone, either a DC supply or PoE. See section .
- **Ethernet.** The phone must be connected to a 10/100BaseT Ethernet network via CAT5 STP cable, no further than 95m from the network switch. See section for connections
- **Earth.** The unit must be connected to equipotential bonding system for the whole area in which the intrinsically safe equipment is being used. See section 4.6.3 for details.
- **Glands.** Glands are not supplied. All glands and cables should comply with IP54 or better to meet 'Increased Safety' ('e' type) requirements. Only 'e' type glands and suitable cables should be used and must be fitted correctly. Note that the environmental rating of the telephone will not exceed that of the glands, i.e. in order to maintain an IP66 rating, glands must also meet IP66.

4.2.3 Cable entries

Auteldac 4 VoIP has 2 cable entry gland positions, but potentially 4 different connections could be made to it:

- Ethernet (always)
- Earth (always)
- Power (if not PoE)
- External relay signal (if required)

Before installing, give consideration to the options available and review the alternative connection schemes in section 4.6.5 to ensure that the required connections can be made using the available glands. For example Power over Ethernet (PoE) is the

recommended method of providing power, to avoid the need for a separate power cable.

If a high voltage is connected to the relay contacts (for example to activate a mains-powered beacon) then that cable **must** be segregated from all other cables and routed through its own gland.

Upon installation care should be taken to ensure that incoming cables are cleanly routed with a view to maintaining segregation from the telephone's internal wiring (i.e. handset, hookswitch, ringer and headset if fitted).

4.3 Dimensions

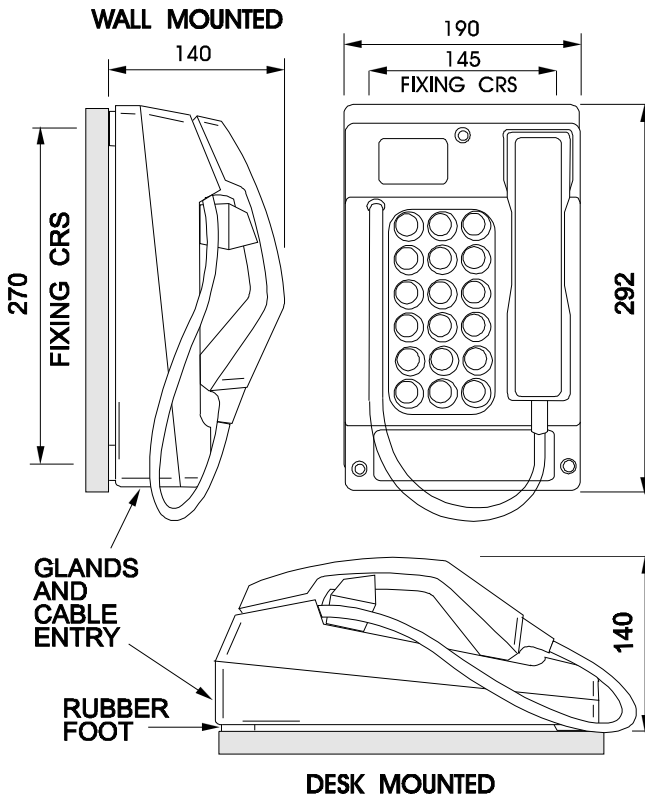

Four 7mm-clearance holes in the Rear Casing (outside the environmental seal) allow it to be screwed or bolted to a wall, or to a pole-side mounting kit (part no 100-02-0208-001).

The holes are arranged in a rectangle, as follows -

- Horizontal separation between centres: 145.0mm (5.7in)

- Vertical separation between centres: 270.0mm (10.6in). The lower pair are about 10mm (0.4in) up from the bottom edge of the unit.

Handset cord lengths:

Standard curled cord: 320mm extending to 1m (13 to 39in).

Standard stainless steel cord: 755mm (29.7in).

Other cord lengths are available as special options: contact GAI-Tronics for details.

4.4 Preparation

ALL POSSIBLE MEASURES MUST BE TAKEN TO ENSURE WATER, FLUID OR DUST DOES NOT CONTAMINATE THE INTERNAL COMPONENTS OF THE TELEPHONE WHILST UNPACKING, PREPARING AND INSTALLING IT IN INCLEMENT WEATHER CONDITIONS OR BY NEGLIGENCE.

FAILURE TO TAKE THIS PRECAUTION WILL INVALIDATE YOUR WARRANTY AND CERTIFICATION

The telephone body must **NOT** be opened, nor glands removed or cables disconnected unless all supplies to the telephone, including network cables, power cables and external devices have been isolated outside the hazardous area. Terminals for incoming cables are 'e' type and must be carefully connected so as to make an 'e' type termination.

The Code of Practice for 'e' type enclosures is specified in EN60079-14 2003. The installer and all service personnel should be familiar with the relevant sections of these documents.

If only one gland entry is used, the sealing plug fitted to the second gland position should be left in place.

1. Place the telephone on its base on a firm horizontal surface.
2. Using a 5mm Allen key, release the Front Casing from the Rear Casing. The screws are captive in the Front Casing.
3. Noting the positions, disconnect the keypad cable at the keypad.
See
4. Disconnect the ringer cable from header HD1 in the rear section, see
5. Take care when removing the Front Casing from the Rear Casing and storing the Front Casing not to damage the internal electronics, specifically the headset switch terminals or connector PCB if fitted.
To do so will violate the certification of the telephone product.
6. Remove the RED blanking plug from the cable entry hole leaving the EE e certified (usually BLACK) blanking plug in situ.

NOTE: The EEx e plug must be used to seal the unused gland hole; failure to do so will invalidate the certification of the telephone product.

7. Select the appropriate size Ex gland for the cable used.
8. Take care when inserting the selected gland into the threaded cable entry hole. Follow the gland manufacturers instructions particularly with respect to sealing, installation and earthing.
9. After the glands have been fitted select the required mounting method and follow the appropriate instructions below.

4.5 Mounting Methods

4.5.1 Wall Mounting

To ensure weatherproof integrity when wall mounted, external cables should enter the enclosure from the bottom via the two 20mm gland entries provided.

IMPORTANT WARNING:

DO NOT DRILL ANY EXTRA HOLES AS THIS WILL INVALIDATE YOUR WARRANTY AND THE CERTIFICATION.

1. Remove rubber feet from the Rear Casing if fitted. Ensuring that the cable entries are at the bottom offer the Rear Casing up to the vertical surface and mark through the fixing holes.
Do not use the Rear Casing as a template to drill the holes. Work only from the marked positions.
2. Drill the holes in the vertical surface to suit the best method of fixing.
3. Ensure the Rear Casing is securely attached to the vertical surface using the four 7mm diameter screw holes provided. No sealing washers are necessary.

IMPORTANT: Do not use countersunk headed fixing screws. Only use round head, socket cap head or pan head screws. Take care not to over tighten the screws as doing so may damage the case and will invalidate your warranty and the certification.

4. Pass the cable through the gland and tighten, following the gland manufacturer's instructions.
5. Continue the installation procedure with the connection of individual wires from the cable as described under sections 4.6 onwards.

4.5.2 Pole-side Mounting

Kit No 100-02-0208-001

This accessory kit is for mounting GAI-Tronics telephones on to the side of round poles of 100mm to 200mm diameter, or on to square or rectangular section uprights of 100mm to 150mm across the mounting surface. For flat mounting on surfaces greater than 150mm across use the desk or wall mounted methods as appropriate.

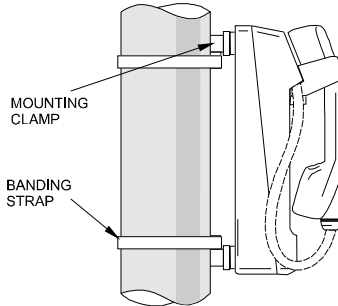

Pole side mounting

NOTE:

Banding straps (large scale worm-drive clamps) are not included in this kit and must be obtained separately. For details of where mounting kits can be obtained, refer to GAI-Tronics .

1. Remove rubber feet from the Rear Casing if fitted. Attach the pole mounting clamp assemblies to the Rear Casing using the M6 x 25 screws provided.
2. Ensuring that the glands are at the bottom, pass a proprietary banding strap round each of the pole mounting clamps and the support pole. Tighten securely.
3. Continue the installation procedure with the connection of individual wires from the cable as described under sections 4.6 onwards.
4. Secure the telephone Front Casing to the Rear Casing.
5. Re-tighten the straps firmly and trim off any excess band material. For security the driving head of the band may also be sawn off.

4.5.3 Desk Mounting / Rake

IMPORTANT WARNING:- Risk of impact or falling

This telephone, when used in a desk mounting mode, should be located on a horizontal, flat non-slip surface. Due to the heavy and robust construction of the unit, users must take care when using the handset or headset, not to pull the cord to such an extent as to cause the telephone to be pulled off the flat surface, and possibly cause damage or injury to persons or equipment. Therefore it is recommended that the

unit be fixed in position using fixing positions and method detailed in section 4.5 if there is any risk of the unit being dislodged as described above.

To provide a 'rake' for convenient operation, the Front Casing may be turned through 180° before it is fitted to the Rear Casing. Thus the cable entries are at the rear of the telephone.

1. Ensure that the supplied rubber feet are fitted to the underside of the Rear Casing if the telephone is not fixed into position.
2. Rotate the Front Casing through 180° and fold the keypad ribbon cable to ensure that it lays flat against the potted block when re-assembled. Refer to Ribbon cable positions (page 19)
3. Continue the installation procedure with the connection of individual wires from the cable as described in sections 4.6 onwards.

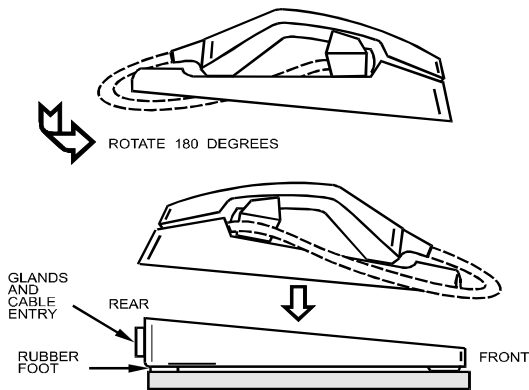

Providing the rake

4.6 Connections and Cabling

IMPORTANT WARNING:-

ISOLATE POWER AND NETWORK OUTSIDE THE HAZARDOUS AREA BEFORE OPENING THE CASE.

ALL TERMINALS MUST BE CONNECTED IN ACCORDANCE WITH THIS INSTALLATION GUIDE. ANY DEVIATION FROM THIS MAY RESULT IN AN UNSAFE INSTALLATION AND VIOLATE THE CONDITIONS OF THE CERTIFICATION.

Make the following connections to the unit:

- Ethernet (including shield connection to STP cable)
- Power (either PoE or separate dc supply)
- Earth (to the system equipotentially bonded earth point)
- External relay (if required)

Details of each connection are given below. There are a number of possible cabling schemes illustrated at the end of the section

4.6.1 Ethernet connections

The Ethernet port is provided on 8 spring terminals on connectors CON2, CON3 and CON4 as follows:

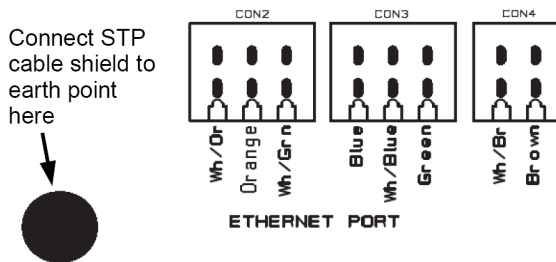

Connect the standard colour-coded cables to the terminals as shown.

Note that the Ethernet cable must be CAT-5 or equivalent STP (shielded twisted pair) and that the shield must be terminated to the earth point as shown.

4.6.2 Power connections

Power can be provided either:

- Via Power-over-Ethernet (PoE), IEEE 802.3af compliant.
NOTE: PoE can only be provided on spare pair (Alternative B), not data pair. Ensure that your PoE switch or injector can provide PoE by this method.

Or

- Isolated DC supply on CON 6:
24 – 48Vdc nominal (the limits are 22-53Vdc)
250mA

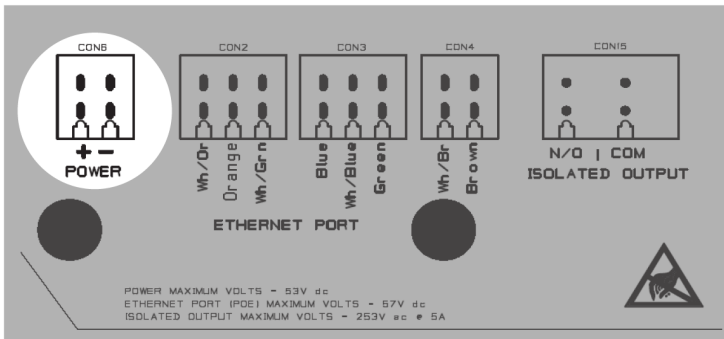

4.6.3 Earth connection

The Auteldac 4 VoIP has an earth point which needs to be connected to the equipotential bonding system for the whole area in which the intrinsically safe equipment is being used, using one of the following:

1. At least two separate conductors each with a minimum copper cross sectional area of 1.5mm^2 (15AWG).

Or

2. At least one conductor with a minimum copper cross sectional area of 4mm^2 (11AWG).

The earth point is connected to 2 earth studs on the case – one available externally and one internally.

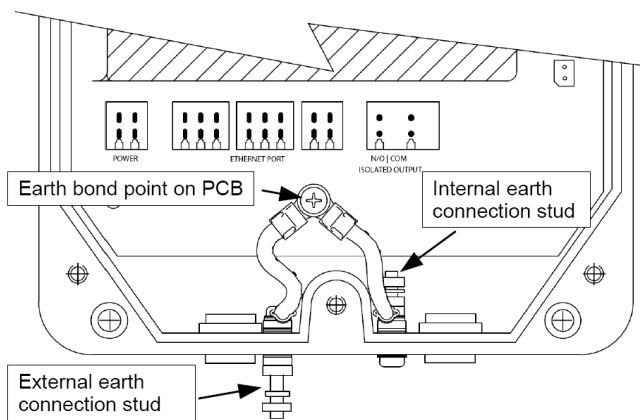

4.6.4 External relay connections

Auteldac 4 VoIP is equipped with a single, normally open relay contact on CON15:

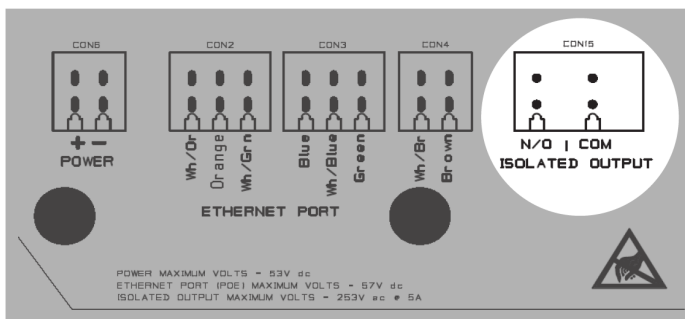

This contact is programmable via the unit's web pages to give a variety of different functions, such as activation on ringing, or off-hook, etc. Refer to the configuration guide for full details (available from www.gai-tronics.co.uk/voipsupport.htm)

CONTACT RATING:

Maximum voltage = 253Vrms (nominal 230V)

Maximum current = 5A

Note: no fusing or transient protection is provided; this must be installed externally.

The relay fitted to the Auteldac 4 VoIP has a continuous current rating of 5A. It has been brought to our attention that some beacons, whilst having a current rating well below this figure, actually generate

current spikes far in excess of this during making and breaking of the relay contacts. These current spikes can cause the relay contacts to fail.

GAI-Tronics have been working closely with a leading beacon manufacturer to resolve this issue and our recommendations are:

- Restrict the use of beacons to non AC variants only or those with a maximum flash intensity of 5 joules.
- Where beacons with greater than 5 joule flash intensity are required, the beacons should be purchased directly from GAI-Tronics, who will ensure compatibility with the Auteldac 4 and that ATEX approvals are not compromised.

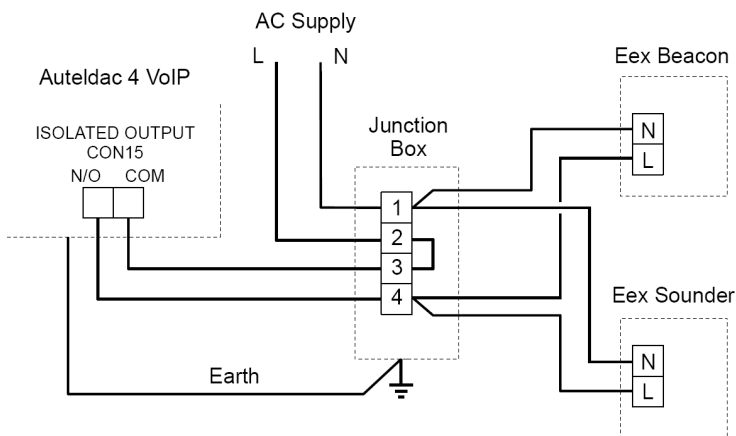

Typical connection scheme for a beacon and sounder

4.6.5 Alternative cabling schemes

Upon installation care should be taken to ensure that incoming cables are cleanly routed with a view to maintaining segregation from the telephone's internal wiring (i.e. handset, hookswitch, ringer and headset if fitted).

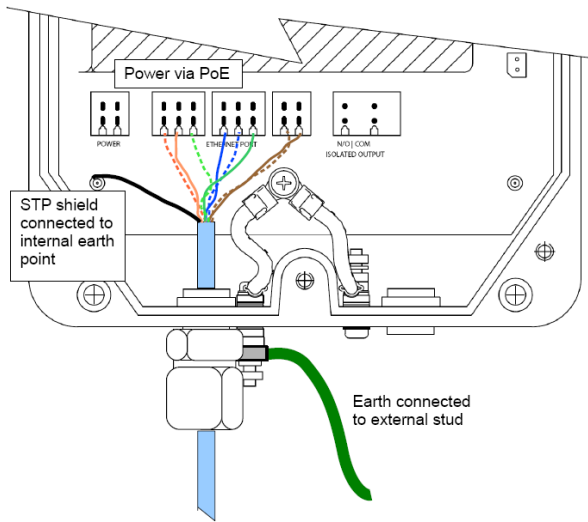

Standard connection – PoE and external earth bond

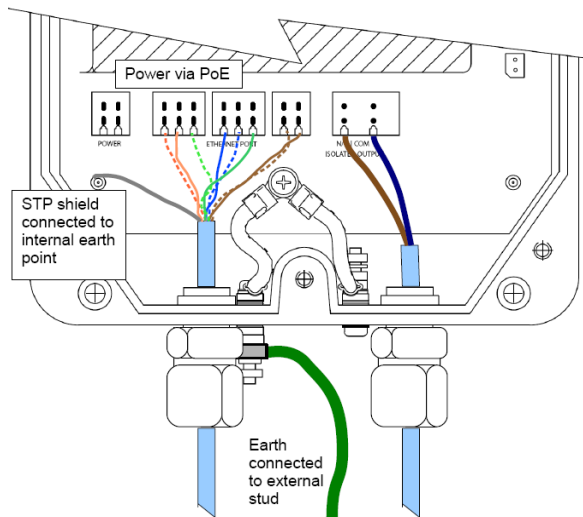

Standard connection – PoE and external earth bond, showing cable routing to isolated output terminals

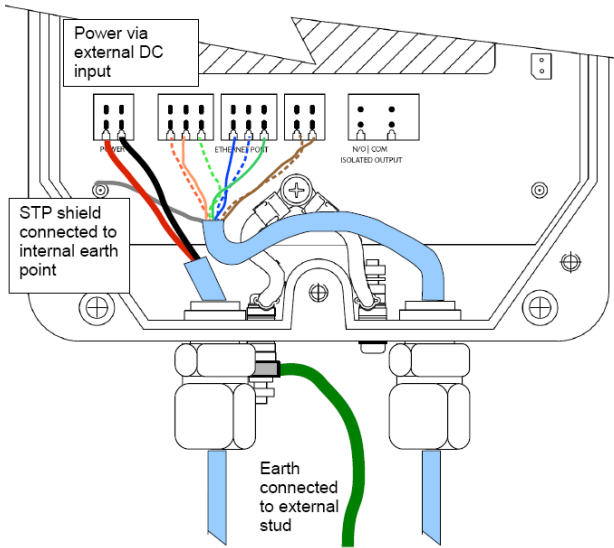

Separate DC power and Ethernet connections

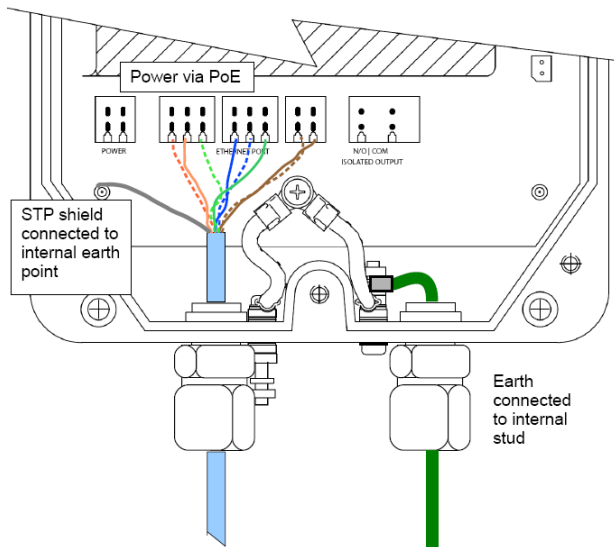

PoE with internal earth bond

4.7 Option Settings, Configuration and Programming

Auteldac 4 VoIP has no internal switches or jumpers. No option settings are made on the telephone itself. All option settings, configuration and programming is done remotely via the unit's web pages or by using a configuration file. Please refer to the separate configuration guide for full details, available from:

www.gai-tronics.co.uk/voipsupport.htm

Please note: the configuration guide covers all models of GAI-Tronics VoIP telephone. Specifically the Auteldac 4 VoIP does not include the following features:

- External inputs
- LEDs
- Serial port
- Only a single relay (OUTPUT1) is fitted.

4.8 Assembly of Telephone on to Installed Base

1. Ensure that the keypad connection between the base and the keypad PCB is made observing the correct orientation of the connector. A keyway on the connector facilitates ensuring that the ribbon cable connector is correctly orientated. Do not forcibly fit the connectors

IMPORTANT – FAILURE TO ENSURE THE CORRECT ORIENTATION OF THE CONNECTOR WILL VIOLATE THE CONDITIONS OF THE CERTIFICATION

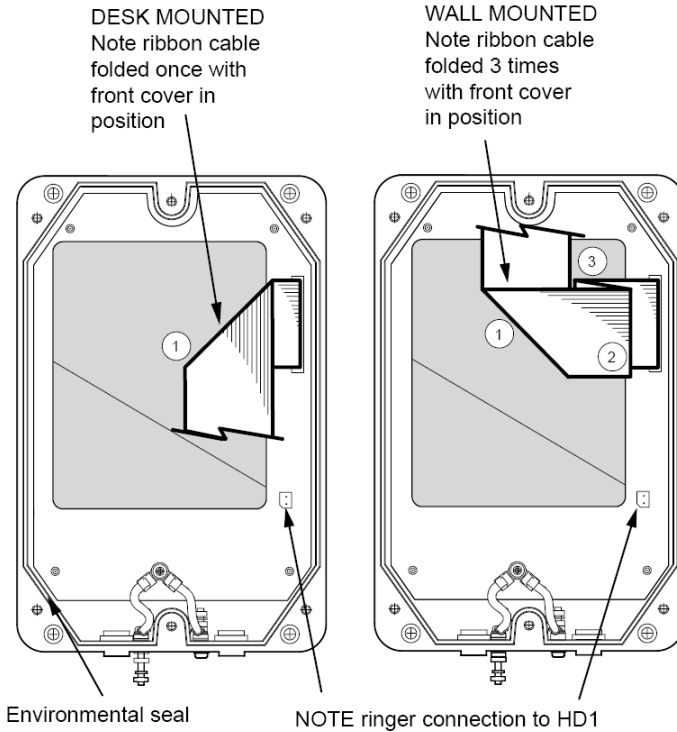

Ribbon cable positions

2. Ensure that the ringer connection is connected from the front case to HD1 on the main PCB in the rear case.
3. Offer the Front Casing to the Rear Casing, with the ribbon cable appropriately folded as shown in figure 8; ensure that the cable will not be trapped when the Front Casing is tightened down. Take care that all folds are made, the ribbon cable can lay flat and that the insulation can not become damaged.
IMPORTANT - DAMAGED INSULATION WILL VIOLATE THE CONDITIONS OF THE CERTIFICATION.
Check also that the environmental seal is in position.
4. Upon installation care should be taken to ensure that incoming cables are cleanly routed with a view to maintaining segregation from the telephone's internal wiring (i.e. handset, hookswitch, ringer and headset if fitted).
5. Tighten the three securing screws firmly.

5 OPERATION

Note that features may vary according to the model supplied, and that certain features are user-programmable. Please see the configuration guide for full details.

5.1 Making and Receiving Calls

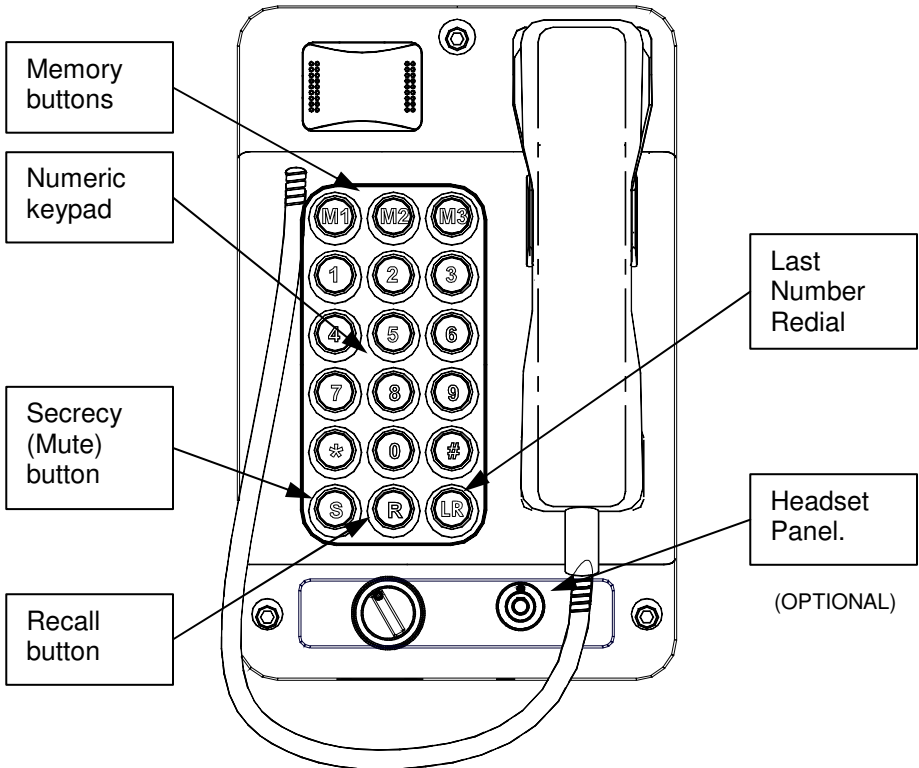

- To make a call, lift the handset, wait for dial tone, dial required digits (or press required memory button or Last Number Redial where fitted) and wait for connection.
- Memory buttons are associated with memory lists (on the [Dialling and Memories / Memory Lists](#) web page), ie M1 will trigger memory list 1, M2 memory list 2, etc.
- For hot-dial versions (i.e. no buttons fitted), the OFFHOOK memory list ([Dialling and Memories / Basic Info](#) web page) should be used to make outgoing calls.

- To end a call, replace the handset in its cradle.
- To receive a call, lift the handset when ringing is heard.
- Take care, if using a model with either a long handset cord or optional headset, not to allow cables to tangle or snare around the body or neck.

5.2 Last Number Redial

(15 and 18 button versions only)

Press LR to redial the last dialled number.

5.3 Recall Function

(15 and 18 button versions only)

The R button can be used to pulse a relay in a remote GAI-Tronics VoIP telephone, for example to activate a door lock release. Please see the configuration guide for full details.

5.4 Secrecy or Mute Function

(15 and 18 button versions only)

During a call, press and hold the S button to mute the microphone.

5.5 Headset Operation

The Auteldac 4 VoIP can be supplied fitted with a headset option, permitting hands-free operation. Only use the approved GAI-Tronics supplied headset and headset extension cable.

To use:

1. Insert headset plug into marked connector, observing keyway.
2. To make or answer a call, turn the switch to the 'I' position.
3. To terminate the call, turn the switch to the 'O' position.
4. To remove the headset, pull the body of the connector to release the latching mechanism. Do not attempt to disconnect the headset by pulling the cable as damage may result.

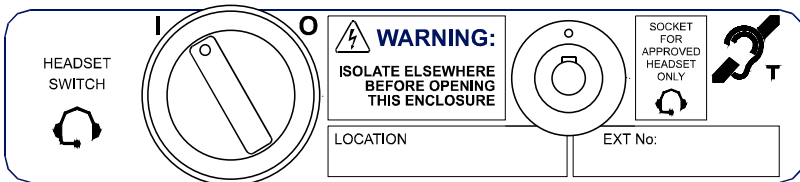
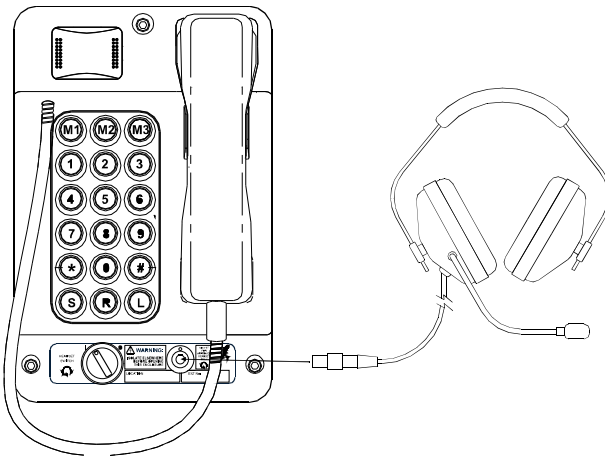

NOTE: If the handset is lifted during a call using the headset, the handset microphone will be muted. The handset can be used normally if a call is not in progress via the headset.

The headset must be used in accordance with the manufacturer's manual (supplied with headset).

The headset interface of the Auteldac 4 VoIP has been certified as intrinsically safe. Therefore, it is permissible to connect and disconnect the headset in a hazardous area.

6 MAINTENANCE

The Auteldac 4 VoIP is based on highly reliable integrated circuits. Under normal operation, the telephone is maintenance free.

6.1 Procedures

A programme of regular external visual inspection and cleaning is recommended, with particular attention being paid to -

On all models:

- Overall cleanliness of the telephone:
Wipe clean as necessary with a cloth dampened with clear water.
If heavily soiled, a little dishwashing liquid may be used in addition.
NOTE: high pressure hoses should not be used for cleaning.
- Security of the installation on wall, pole or post.
- Security and integrity of cable entries.
- Security of the three body screws.
- Cleanliness, integrity and condition of the handset:
Wipe clean as necessary with a cloth dampened with clear water, and disinfect the handset.
Note that the handset has an anti-static coating – take care not to damage this by excessive rubbing or the use of chemicals or solvents (e.g. petroleum spirit). Do not allow liquid to penetrate the earpiece or mouthpiece.
- Security and condition of the handset cable.

On headset models, refer to headset manufacturer's manual for cleaning, hygiene and maintenance of headset.

6.2 Fault Finding & Field Repairs

The Auteldac 4 VoIP contains no user serviceable parts and in the event of damage or failure must be replaced with a tested telephone of the correct type.

Refer to section 6.3 for a list of possible fault conditions.

6.3 Possible Operating Faults

The following operating and installation conditions could give rise to faults. During installation, or in the event of a fault, please ensure that the following do not occur:

- Water ingress
- Incorrect positioning of ribbon cable (Section 4.8)
- Damage to any internal components
- Overstressing of screws
- Insecure fixing
- Incorrect installation of glands (Section 4.4)
- Incorrect wiring or cable connections (Section 4.6)
- Improper reassembly following connection
- Additional holes drilled in casing

7 TECHNICAL SPECIFICATIONS

7.1 Suitability for Use

It is the responsibility of the installer or user to determine whether or not Auteldac 4 VoIP is suitable for use in a given location or particular circumstances.

7.2 Product Features

Power supply	Power-over-Ethernet, IEEE 802.3af compliant, (alternative B only, ie spare pair not data pair), maximum voltage 57V or External power supply: 24-48Vdc nominal, 250mA. Limits 22-53V. A separate, isolated supply must be provided for each telephone.	
Hookswitch	Electronic with no external moving parts	
Ringer loudness	Maximum 90dBA @ 1m	
Handset	Suitable for inductive coupling to Hearing Aids having a `T' switch position. Tested to ETS 300-381	
Network	10/100 BaseT Ethernet RJ45, Cat5 or Cat5e UTP Static IP provisioning or DHCP STUN client (NAT traversal)	
Call control signalling	SIP (RFC3261 compliant) Loose routing	
External inputs	None	
External outputs	Output 1 - rating 5A at 250Vac.	
Codecs	G.711 A-Law G.711 μ -Law G.722 G.729 G.723.1 MP-MLQ G.723.1 ACELP Codec preference sequence DTMF in-band / out-of-band (RFC2833) Configurable comfort tones (to emulate national tones)	

Configuration	Embedded web server Embedded Telnet server Configuration file download Configuration file building tool (Vconf.exe) Command line interface SNTP with timezone and daylight saving Automatic updating via TFTP Password protection
Monitoring and reporting	Real-time over TCP/IP Syslog application or email Embedded SMTP client Automatic fault reporting Handset integrity monitoring
Call diversion (on auto-dial)	Configurable call lists (max 20 entries) Numbers or URIs (with comfort tones) Divert to next in list if the call fails

7.3 Headset

For models fitted with headset socket, use only GAI-Tronics ATEX headset part number 100-02-0598-001. See section 5.5 for operation.

NOTE:

GAI-Tronics only currently supply an ATEX certified headset. No IEC certified is available. IEC certification will be invalidated if an ATEX headset is connected.

Headset certification details:

 II 2 G

EEx ib IIC T4 (-20°C ≤ T_a ≤ 40°C)

TUV03ATEX2124

NOTE: the headset temperature class is T4 only. With the headset fitted, the temperature class of the complete instrument is that of the headset.

The headset must only be used in accordance with the supplied manufacturer's manual.

7.3.1 Optional Headset Extension lead

The standard headset cord is approximately 820mm long and can extend to approximately 2m (dependant on safe operating conditions.)

A separate headset extension lead is available as an optional extra (part No. 610-35-2036-001). This will allow the operator to use the headset over 6 metres away from the telephone unit. Note: Refer to section 1 for hazard warnings regarding long corded Headsets & handsets.

7.4 Physical Characteristics

Casing material	Carbon loaded glass filled polyester body - rugged and corrosion free
Handset Material	Cycloy (2850) with stainless steel or polyester curled cord.
Weight	3.2kg (7lbs)
Dimensions	190W x 292H x 140D mm overall (7.5 x 11.5 x 5.5 in) Standard handset cord lengths: Curled cord: 320mm extending to 1000mm (13-39in) Armoured steel cord: 755mm (29.7in)

7.5 Environmental Considerations

WARNING: The telephone must only be **stored and operated** within the temperature ranges stated below. Subjecting the telephone to temperatures outside these ranges will shorten the life of its electronic components.

Storage temperature range	-20°C to +50°C (-4°F to 122°F)
Operating temperature range	-20°C to +50°C (-4°F to 122°F)
Maximum relative humidity	95% non condensing
Telephone enclosure IP Rating:	IP65 (curly cord variants) IP54 (steel cord variants) <i>(NB the handset is excluded from this rating)</i>
The Auteldac 4 VoIP has not been certified for installation or operation in explosive dust atmospheres.	
High pressure hoses should not be used on this product.	

7.6 Related Standards and Regulations

Auteldac 4 VoIP is fully compliant with the following:

7.6.1 ATEX Hazardous Area Certification

EN60079-0:2006	Electrical apparatus for explosive gas atmospheres Part 0: General requirements.
IEC60079-0:2007	Electrical apparatus for explosive gas atmospheres Part 0: General requirements.
EN60079-7:2007	Electrical apparatus for explosive gas atmospheres Part 7: Increased safety 'e'.

EN60079-11:2007	Electrical apparatus for explosive gas atmospheres Part 11: Protection by intrinsic safety 'i'.
EN60079-18:2004	Electrical apparatus for explosive gas atmospheres Part 18: Construction, test and marking of type of protection encapsulation 'm' electrical apparatus.

Certification details:

⊕ II 2 G Ex e ib mb IIC T4 Gb (-20°C to +50°C)

Baseefa09ATEX0261

A facsimile of the ATEX certificate is in section 8.

7.6.2 IEC Ex Certification

IEC 60079-0: 2004 Edition: 4.0	Electrical apparatus for explosive gas atmospheres - Part 0: General requirements
IEC 60079-0: 2007-10 Edition: 5	Explosive atmospheres - Part 0: Equipment - General requirements
IEC 60079-7: 2006-07 Edition: 4	Explosive atmospheres - Part 7: Equipment protection by increased safety 'e'
IEC 60079-11:2006 Edition: 5	Explosive atmospheres - Part 11: Equipment protection by intrinsic safety 'i'
IEC 60079-18 : 2004 Edition: 2.0	Electrical apparatus for explosive gas atmospheres - Part 18: Construction, test and marking of type of protection encapsulation 'm' electrical apparatus

Certification details:

IECEX BAS 09.0126

Ex e ib mb IIC T4 Gb (-20°C to +50°C)

A facsimile of the IECEx certificate is in section 9.

7.6.3 EMC Testing to:

EN55022:2006 (Class B) – Information technology equipment. Radio disturbance characteristics.

EN55024:1998 – Information technology equipment. Immunity characteristics.

7.6.4 European Directives:

1999/5/EC – European Radio Equipment & Telecommunications Terminal Equipment Directive.

94/9/EC - ATEX Product Directive.



This mark indicates compliance with the following directives for this product;

ATEX Product Directive 94/9/EC

Ex II 2 G

Ex e ib mb IIC T4 Gb (-20°C to +50°C)

Baseefa09ATEX0261



Suitable for inductively coupling to Hearing Aids having a `T' switch position. Use of this facility for any other purpose than that for which it was intended may cause degradation in quality of a connection.

Tested to ETS 300-381



The GAI-Tronics Quality Management System has been approved by LRQA to ISO9001-2000. Certificate No. 861888

7.7 Recycling Information

The symbol shown here and on the product means that the product is classed as Electrical or Electronic Equipment and should not be disposed with other household or commercial waste at the end of its working life.



The Waste of Electrical and Electronic Equipment (WEEE) Directive has been put in place to recycle products using best available recovery and recycling techniques to minimise the impact on the environment, treat any hazardous substances and avoid the increasing landfill.

Business users should contact their suppliers and check the terms and conditions of the purchase contract and ensure that this product is not mixed with other commercial waste for disposal.

8 ATEX certificate

Certificate Number
Baseefa09ATEX0261



Issued 10 September 2009
Page 1 of 3

1 EC - TYPE EXAMINATION CERTIFICATE

2 Equipment or Protective System Intended for use in Potentially Explosive Atmospheres Directive 94/9/EC

3 EC - Type Examination Certificate Number: **Baseefa09ATEX0261**

4 Equipment or Protective System: **Auteldac 4 Voip**

5 Manufacturer: **Gai-Tronics (A Division of Hubbell Limited)**

6 Address: **Burton-Upon-Trent, Staffordshire, DE13 0BZ**

7 This equipment or protective system and any acceptable variation thereto is specified in the schedule to this certificate and the documents therein referred to.

8 Baseefa, Notified Body number 1180, in accordance with Article 9 of the Council Directive 94/9/EC of 23 March 1994, certifies that this equipment or protective system has been found to comply with the Essential Health and Safety Requirements relating to the design and construction of equipment and protective systems intended for use in potentially explosive atmospheres given in Annex II to the Directive.

The examination and test results are recorded in confidential Report Nos. (see schedule)

9 Compliance with the Essential Health and Safety Requirements has been assured by compliance with:

EN 60079-0:2006, IEC 60079-7:2007, EN 60079-7:2007, EN 60079-11:2007, EN 60079-18:2004

except in respect of those requirements listed at item 18 of the Schedule.

10 If the sign "X" is placed after the certificate number, it indicates that the equipment or protective system is subject to special conditions for safe use specified in the schedule to this certificate.

11 This EC - TYPE EXAMINATION CERTIFICATE relates only to the design and construction of the specified equipment or protective system. Further requirements of the Directive apply to the manufacturing process and supply of this equipment or protective system. These are not covered by this certificate.

12 The marking of the equipment or protective system shall include the following :

Ⓔ II 2G Ex e Ib mb IIC T4 Gb (-20°C to +50°C)

This certificate may only be reproduced in its entirety, without any change, schedule included.

Baseefa Customer Reference No. 0752

Project File No. 07/0430

This certificate is granted subject to the general terms and conditions of Baseefa. It does not necessarily indicate that the equipment may be used in particular industries or circumstances.

Baseefa

Rockhead Business Park, Staden Lane,
Buxton, Derbyshire SK17 9RZ
Telephone +44 (0) 1298 766600 Fax +44 (0) 1298 766601
e-mail info@baseefa.com web site www.baseefa.com
Baseefa is a trading name of Baseefa Ltd
Registered in England No. 4305578. Registered address as above.



R S SINCLAIR
DIRECTOR
On behalf of
Baseefa



13

Schedule

14

Certificate Number Baseefa09ATEX0261

15 Description of Equipment or Protective System

The Auteldac 4 Voip is a rugged weatherproof telephone for use in explosive atmospheres.

The handset may be supplied with either a curly or a stainless steel cord. The optional keypad may have 12, 15 or 18 buttons. The telephone comprises three Printed Circuit Boards (PCB's) inside a non-metallic enclosure. Most of the main PCB is encapsulated apart from selection and wiring terminals.

The external terminations are made via Ex e approved cable glands at Ex e approved terminal blocks. An optional plug and socket are present for connections to an external headset.

The Auteldac 4 Voip is designed to be powered over the incoming Ethernet connections from a supply conforming to IEEB802.3:2002 or via a 57V d.c. maximum supply connected to the Power terminals.

16 Report Number

GB/BAS/ExTR09.0254/00 & GB/BAS/ExTR09.0255/00

17 Special Conditions for Safe Use

None

18 Essential Health and Safety Requirements

All relevant Essential Health and Safety Requirements are covered by the standards listed at item 9.

19 Drawings and Documents

Number	Sheet	Issue	Date	Description
212-01-7000-000	1	1	09.09.09	Auteldac 4 Voip Block Diagram
212-01-7000-000	2	1	09.09.09	Auteldac 4 Voip External General Arrangement
212-01-7000-000	3	1	09.09.09	Auteldac 4 Voip Internal General Arrangement
212-01-7000-000	4	1	09.09.09	Auteldac 4 Voip Main PCB Physical & Encapsulation Details
212-01-7000-000	5	1	09.09.09	Auteldac 4 Voip Component Details
212-01-7000-000	6	1	09.09.09	Auteldac 4 Voip Certification Label
212-01-7000-000	7	1	09.09.09	Auteldac 4 Voip Enclosure Sealing Details
999-01-1114-000	1	1	09.09.09	VoIP Schematic I/O and IS Circuitry
999-01-1114-000	2	1	09.09.09	VoIP Schematic LAN and PoE
999-01-1114-000	3	1	09.09.09	VoIP Schematic Memory and Serial Ports
999-01-1114-000	4	1	09.09.09	VoIP Schematic Power
999-01-1114-000	5	1	09.09.09	VoIP Schematic Reset / Xtal / Debug
999-01-1114-000	6	1	09.09.09	Auteldac 4 Voip Main PCB Top Artwork
999-01-1114-000	7	1	09.09.09	Auteldac 4 Voip Main PCB Layer 2 Artwork



Number	Sheet	Issue	Date	Description
999-01-1114-000	8	1	09.09.09	Auteldac 4 Voip Main PCB Layer 3 Artwork
999-01-1114-000	9	1	09.09.09	Auteldac 4 Voip Main PCB Layer 4 Artwork
999-01-1114-000	10	1	09.09.09	Auteldac 4 Voip Main PCB Layer 5 Artwork
999-01-1114-000	11	1	09.09.09	Auteldac 4 Voip Main PCB Bottom Artwork
999-01-1114-000	12	1	09.09.09	Auteldac 4 Voip Main PCB Ident Top
999-01-1114-000	13	1	09.09.09	Auteldac 4 Voip Main PCB Ident Bottom
999-01-1116-000	1	1	26.08.09	A4 Voip Keypad Board
999-01-1116-000	2	1	01.09.09	A4 Voip Keypad PCB Top Ident
999-01-1116-000	3	1	01.09.09	A4 Voip Keypad PCB Top Artwork
999-01-1116-000	4	1	01.09.09	A4 Voip Keypad PCB Bottom Artwork
999-01-1050-000	1	3	01Sept09	Headset Interface Schematic
999-01-1050-000	2	3	01Aug05	Headset Interface Schematic Top Artwork
999-01-1050-000	3	3	01Aug05	Headset Interface Schematic Bottom Artwork

9 IECEx certificate

		<h1>IECEx Certificate of Conformity</h1>	
INTERNATIONAL ELECTROTECHNICAL COMMISSION IEC Certification Scheme for Explosive Atmospheres <small>for rules and details of the IECEx Scheme visit www.iecex.com</small>			
Certificate No.:	IECEx BAS 09.0128	Issue No.: 0	Certificate history:
Status:	Current		
Date of Issue:	2009-09-10	Page 1 of 3	
Applicant:	Gai-Tronics (A Division of Hubbell Limited) Brunel Drive Stretton Business Park Burton-Upon-Trent Staffordshire DE13 0BZ United Kingdom		
Electrical Apparatus: Optional accessory:	Auteldac 4 VOIP		
Type of Protection:	Intrinsic Safety, Increased Safety, Encapsulation		
Marking:	Ex e Ib mb IIC T4 Gb (-20°C to +50°C)		
Approved for issue on behalf of the IECEx Certification Body:	R S Sinclair		
Position:	Managing Director		
Signature: (for printed version)			
Date:	10/9/9		
<ol style="list-style-type: none">1. This certificate and schedule may only be reproduced in full.2. This certificate is not transferable and remains the property of the issuing body.3. The Status and authenticity of this certificate may be verified by visiting the Official IECEx Website.			
Certificate issued by:	Baseefa Rockhead Business Park Staden Lane Buxton Derbyshire SK17 9RZ United Kingdom		
			



IECEX Certificate of Conformity

Certificate No.: IECEx BAS 08.0126
Date of Issue: 2009-09-10 Issue No.: 0
Page 2 of 3

Manufacturer: Gal-Tronics (A Division of Hubbell Limited)
Brunel Drive
Stretton Business Park
Burton-Upon-Trent
Staffordshire
DE13 0BZ
United Kingdom

Manufacturing location(s):

This certificate is issued as verification that a sample(s), representative of production, was assessed and tested and found to comply with the IEC Standard list below and that the manufacturer's quality system, relating to the Ex products covered by this certificate, was assessed and found to comply with the IECEx Quality system requirements. This certificate is granted subject to the conditions as set out in IECEx Scheme Rules, IECEx 02 and Operational Documents as amended.

STANDARDS:

The electrical apparatus and any acceptable variations to it specified in the schedule of this certificate and the identified documents, was found to comply with the following standards:

IEC 60079-0 : 2004 Edition: 4.0	Electrical apparatus for explosive gas atmospheres - Part 0: General requirements
IEC 60079-0 : 2007-10 Edition: 5	Explosive atmospheres - Part 0: Equipment - General requirements
IEC 60079-11 : 2006 Edition: 5	Explosive atmospheres - Part 11: Equipment protection by intrinsic safety "I"
IEC 60079-18 : 2004 Edition: 2.0	Electrical apparatus for explosive gas atmospheres - Part 18: Construction, test and marking of type of protection encapsulation "m" electrical apparatus
IEC 60079-7 : 2006-07 Edition: 4	Explosive atmospheres - Part 7: Equipment protection by increased safety "e"

This Certificate does not indicate compliance with electrical safety and performance requirements other than those expressly included in the Standards listed above.

TEST & ASSESSMENT REPORTS:

A sample(s) of the equipment listed has successfully met the examination and test requirements as recorded in

Test Report:

GB/BAS/ExTR08.0254/00
GB/BAS/ExTR08.0255/00

Quality Assessment Report
GB/BAS/QAR06.0039/02



IECEX Certificate of Conformity

Certificate No.: IECEx BAS 09.0126

Date of Issue: 2009-09-10

Issue No.: 0

Page 3 of 3

Schedule

EQUIPMENT:

Equipment and systems covered by this certificate are as follows:

The Auteldac 4 Voip is a rugged weatherproof telephone for use in explosive atmospheres.

The handset may be supplied with either a curly or a stainless steel cord. The optional keypad may have 12, 15 or 18 buttons. The telephone comprises three Printed Circuit Boards (PCBs) inside a non-metallic enclosure. Most of the main PCB is encapsulated apart from selection and wiring terminals.

The external terminations are made via Ex e approved cable glands at Ex e approved terminal blocks. An optional plug and socket are present for connections to an external headset.

The Auteldac 4 Voip is designed to be powered over the incoming Ethernet connections from a supply conforming to IEEE802.3.2002 or via a 57V d.c. maximum supply connected to the Power terminals.

CONDITIONS OF CERTIFICATION: NO

10 CE DECLARATION

GAI-Tronics A Division of Hubbell Ltd Declaration of Conformity

We, GAI-Tronics (a division of Hubbell Ltd.), of Brunel Drive, Stretton Business Park, Burton upon Trent, Staffordshire, England, DE13 0BZ, declare under our sole responsibility, that the following product is in conformity with the directives and standards listed below and hold the relevant technical documentation at the above address.

Product description	IECEx & ATEX Approved Hazardous Area Telephone Auteldac 4 VoIP
Product part number range	212-02-7XXX-XXX

EC Directive	Standards applicable under the Directive
1999/5/EC – European Radio & Telecommunications Terminal Equipment Directive. Equipment or Protective System Intended for use in Potentially Explosive Atmospheres Directive 94/9/EC.	EN55022:2006 (Class B) – Information technology equipment. Radio disturbance characteristics. EN55024:1998 (+A1:2001 + A2:2003) – Information technology equipment. Immunity characteristics. EN60079-0:2006 - Electrical apparatus for explosive gas atmospheres Part 0: General requirements. EN60079-0:2007 - Electrical apparatus for explosive gas atmospheres Part 0: General requirements. EN60079-7:2007 - Electrical apparatus for explosive gas atmospheres Part 7: Increased safety 'e'. EN60079-11:2007 - Electrical apparatus for explosive gas atmospheres Part 11: Protection by intrinsic safety 'i'. EN60079-18:2004 - Electrical apparatus for explosive gas atmospheres Part 18: Construction, test and marking of type of protection encapsulation 'm' electrical apparatus.
2002/95/EC - Restriction of the use of certain hazardous substances in electrical and electronic equipment (RoHS)	Complies
2002/96/EC 2003/108/EC Waste Electrical and Electronic Equipment Directive (WEEE)	Complies

Notified Body	Baseefa, Rockhead Business Park, Staden Lane, Buxton, Derbyshire UK. SK17 9RZ 1180
Identification Number	Baseefa09ATEX0261
EC Type Examination Certificate Number	Group II, Category 2G (Ex e ib mb IIC T4 Gb (-20°C to +50 °C))
IECEx Examination Certificate Number & Markings	IECEx BAS 09.0126 Ex e ib mb IIC T4 Gb (-20°C to +50 °C)

Date of issue	Name of authorised signatory	Signature of signatory
4-2-2010	G Lines Business Unit General Manager	

C/N32568-027 File 212-40-7XXXa1.pdf

QC 300 / 9

11 Licensing Notices

The firmware in GAI-Tronics VoIP products contains modules subject to licensing and copyright as follows:

Module	License
u-boot	GPL V2
Linux kernel	GPL V2
Busybox	GPL V2
Opal/PWLib	Mozilla Public License V1.1
Modutils	GPL V2
MTD	GPL V2
NTP	David L. Mills Copyright Notice

These licence and copyright notices are available in full from our website at
www.gai-tronics.co.uk/voipsupport.htm

GAI-TRONICS

A division of Hubbell Ltd.

Brunel Drive

Stretton Park

Burton upon Trent

Staffordshire

DE13 0BZ

www.gai-tronics.co.uk

Tel: +44 (0)1283 500 500

Fax: +44 (0)1283 500 400

If you have any difficulties, please call.

The policy of GAI-Tronics is one of continuous improvement,
therefore the Company reserves the right to change
specifications without notice.

The contents of this publication are confidential, are the property of GAI-Tronics, and may not
be reproduced, wholly or in part, without their written permission.

E&OE.